

Signal analyser, the software support for education of signal processing

Jiří Tůma¹

Analyzátor signálu, programová podpora pre výuku spracovania signálu

The paper deals with the software that is supporting signal-processing lectures given for students of mechanical engineering. An application, named Signal Analyser is written in Visual Basic 6.0 language so it is working under Windows operating systems. The main idea is to demonstrate spectral analysis of signals that are taken from measurements in industry or synthesised by an incorporate signal generator.

Key words: Signals, instruments, signal analysers, post processing, measurement organiser, instrument organiser, graphs, sound cards.

Introduction

Students of the Mechanical Engineering Faculty that are specialized in the field of the control systems and instrumentation are trained to become skilled experts in signal processing. The area, where they benefit from knowledge of the mechanical engineering and computer science, is a diagnostics and experimental dynamics.

As it was mentioned, the paper deals with the software that is supporting signal-processing lectures. An application, named Signal Analyser is written in Visual Basic 6.0 language so it is working under Windows operating systems. Signal Analyser is dedicated to demonstrate spectral analysis of signals that are taken from measurements in industry or synthesized by an incorporate signal generator. Additionally to these, the students can also do their own signal records using a sound card in a PC. The collateral effect of Signal Analyser is aimed at improving student skills in handling with the windows based application supporting a multiple document interface. As it is shown in Figure 1, a user interface in the Signal Analyser application allows having more than one document open at the same time. An important part of signal processing is presentation of results in various types of graphs. Signal Analyser benefits from functionality of a component called Microsoft Graph 9.0 that is an integral part of the Microsoft Office applications. An advantage of this component is that editing uses the same rule as in Excel, therefore everybody can easily change scale, appearance of plots. On the other side, the length of series is limited to 4000 numbers.

Handling with the recorded signal and their processing is based on arranging measurements consisting of generally more signals and instruments into tree structures in separate windows that are named organisers. Solving a task from signal processing means that the user has to make connections between signals and instruments and to set up or parameterise the instruments. The measured and imported data as good as configured and parameterised instruments can be saved in a project file to continue later in work. The user can provide the project with a note in the separate windows (Note for project). This window contains the RichTextBox control, so not only a text but also pictures can be inserted into RichTextBox.

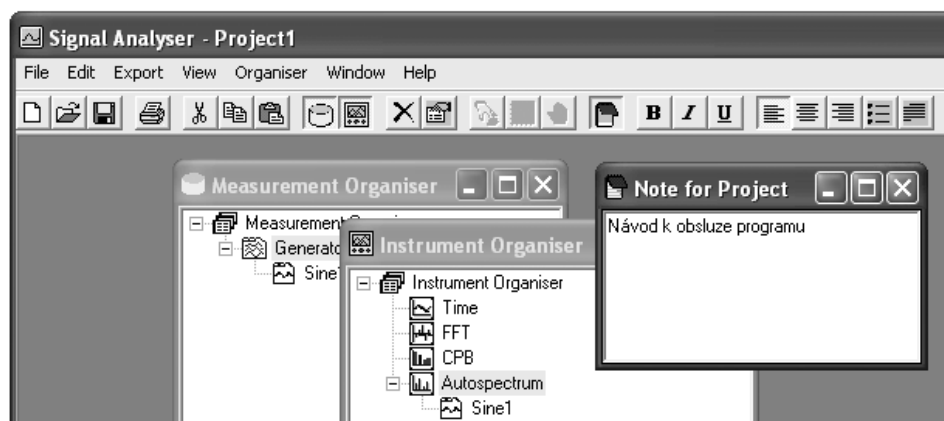

Fig.1. Main program window arranged as a multiple-document interface.

¹ Jiří Tůma: Department of Control Systems & Instrumentation, VŠB - Technical University of Ostrava, 17.listopadu 15, Ostrava-Poruba, 708 33, Czech Republic, tel.: +420 596993482 jiri.tuma@vsb.cz (Recenzovaná a revidovaná verzia dodaná 19.11.2003)

Measurement organiser

The tree view control displays a hierarchical list of items divided into three levels. The root level is on the top of the tree. The second one corresponds to a measurement that is composed of a set of signals with the same sample count and sampling frequency. The third one corresponds to signals. The number of the measurements and the signals associated to the individual measurement can be greater than one. Each measurement and signal has its own properties arranged into the properties window. The measured signals can be displayed in the form of a time history plots. The types of data, which can be imported into the project, are shown in Table 1.

To do student's homework, Signal Analyser can directly record a data via a sound card. The records are intended to be processed by instruments of Signal Analyser. The user can select various parts of the record and save it into the new measurements of the tree view in the measurement organiser. The appropriate window can be open to set up the input volume.











Tab.1. Type of data sources.

Data Source	Description
Binary Data arranged in Columns	16 bits data in binary file
Binary Data from Buf-Files	Binary data in BUF-file
ASCII Data from Clipboard	ASCII data from clipboard
ASCII Data from Text File	ASCII data from text file
Waveform File	Wave file
Waveform Audio Input Device	Data recorded directly from a sound cards
BK 2032 Time	Binary data from BK 2034/32 signal analyser
Signal Generator	Data generated manually or automatically

Instrument organiser

A list of actually available instruments is shown in Table 2. The instruments are based partly on FFT transformation and filtration in the time domain. The special instrument provides evaluating of rotational speed from an impulse signal. The impulse signal can control resampling of signals that are sampled at the fix sampling rate in such a way that the signal records of the fixed length in the number of samples correspond to shaft revolutions to perform the order analysis.

Tab.2. Signal Analyser instruments.

Instrument	Description
 Time	Hilbert transform, envelope a filtration in the frequency domain
 FFT	FFT a filtration in the frequency domain
 CPB	Averaged 1/1-octave a 1/3-octave frequency spectrum
 Autospectrum	Averaged autospectrum a filtration in the frequency domain
 Cross-Spectrum	Averaged cross-spectrum a filtration in the frequency domain
 FRF	Averaged frequency response a filtration in the frequency domain
 Overall	Overall level of signal in RMS or PWR
 Tachometer	RPM evaluated from an impulse signal
 Resampling	Resampling of signal
 Test Unit	Unit is only for demonstrating response of the 2-order system

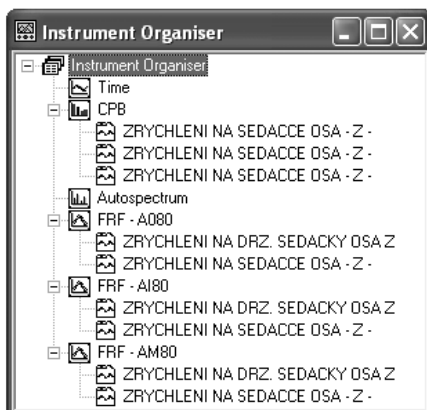

All the instruments are set up and parameterised in the properties window that is associated with each of the instrument type. The instrument input signals are inserted by an item of the main menu or context menu or by using drag and drop technique as well. The result looks like an example that is shown in Figure 2.

The result of evaluation which is done by an instrument are in the form of the single spectrum or multispectrum plots. The software of the Time instrument is designed to demodulate signals containing harmonic components which amplitude or phase are modulated. As the modulation signal is evaluated a record-by-record, the discontinuities are smoothed by the high speed convolution, which is based on the zero

Fig.2. Instruments interfaced to inputs.

padding, FFT, filtration in the frequency domain and inverse FFT transform. The constant percentage band (CPB) analyser is based on the FFT transform. The overall analyser performs the first order filtration of the squared input samples.

The spectrum scale is optionally set up to RMS (Root Mean Square), PWR (Power) or PSD (Power Spectral Density) scale. The results in the form of complex numbers against time or frequency are displayed in the form of the real part, imaginary part, magnitude, phase or Nyquist plots.

Conclusion

The paper is informing on the software that is supporting the signal processing education at the Faculty of Mechanical engineering of VŠB Technical University of Ostrava. The signal processing lectures are extended by a set of exercises based on the measurements performed by a research work for industry. Our students that are working with Signal Analyser can analyse these measurements or make their own noise measurements using a sound card what is the first step to become experts.

Acknowledgements

This research has been conducted at the Technical University of Ostrava as a part of the research project No. MSM 272300012 and has been supported by the Czech Ministry of Education.

References

TŮMA, J.: Zpracování signálů získaných z mechanických systémů užitím FFT. *Sdělovací technika*, Praha, 1997.