

Indirect Distance Measuring as Applied upon both Connecting Surveys and Orientation One

Pavel Černota, Hana Staňková¹ and Silvia Gašincová²

As per Regulation of the Czech Mining Office Board No. 435/1992 of Law Digest, in wording of later rulings, there is a duty to survey any and all mining workings in the state reference system of S-JTSK type. Tasks for both connecting and orientation surveys on the Earth's surface are to identify the end point position for the plummet segment and especially to identify their bearing. Connecting the horizon in the mine plays a role in transferring the coordinate values from said plummet segment to the points ensuring the basic orientation line of the connected mine working. Distance measurement is done by means of survey compared tape. Time demand and difficultness in organizing the works represent a disadvantage of this standard solution. Connecting and Orientation measuring might be executed such a way, that end point coordinates for plummeted segment both on the surface and underground ones are identified thru the total station using the surveying omnidirectional prism inserted coaxially above said plumb bob. Then, distances are not measured using the survey tape, but by means of electronic optical distance meters.

Key word: *Connecting measurement, Orientation measurement, distance, optical distance meter, surface, underground.*

Introduction

As per the Regulation of the Czech Mining Office Board No. 435/1992 of Law Digest, in wording of later rulings, there is a duty to survey any and all mining workings in the state reference system based on ruling of the government of the Czech Republic. Tasks for both connecting and orientation surveys on the Earth's surface are to identify the end point position for the plummet segment (plumb lines) and especially to identify their bearing. Connecting the horizon (underground working) in the mine plays a role in transferring the coordinate values from said plummet segment to the points ensuring the basic orientation line of the connected mine working. Way of connecting survey and orientation measurement is selected respecting the kind of development (underground) working. Solved issues cover horizons opened with a single or multiple-shafts. Distance measurement is done by means of survey compared tape. Time demand and difficultness in organizing the works represent a disadvantage of this standard solution. Connecting and Orientation measuring might be executed such a way, that end point coordinates for plummeted segment both on the surface and underground ones are identified thru the total station using the surveying omnidirectional prism inserted coaxially above said plumb bob. Then, distances are not measured using the survey tape, but by means of electronic optical distance meters. Essence of solution is practical verification of the invention (patent) and as per technical solution (utility design) submitted to the Industrial Property Administration of the Czech Republic.

Use of indirect measuring of distances in connecting and orientation surveying

The drawbacks of the classic measurement of lengths by a tape measure in connecting and orientation surveying are eliminated by the proposed solution of suspending an omnidirectional prism placed coaxially into the plumb bob suspension. The device for such type of measuring is constructed for a coaxial placement of an omnidirectional prism, which comprises of screws for centric fastening of a wire, bush with bearings permitting rotation of the suspension, bearing plates, pin to fix a reflective prism, omnidirectional prism, rods connecting the upper and lower bearing plates of the suspension – See Fig. 1. This device may be applied for all connecting and orientation measurements when at least one opening is a shaft.

The method of connecting and orientation measurement is implemented casting one or two plummet lines down a shaft (according to the opening mode) on a steel wire with suspensions for a coaxially placed omnidirectional prism – See Fig. 2. The coordinates of the projected plummet position on the surface (at the shaft mouth) are defined by a direction and length measuring from known points whose position is set in the national reference system (S-JTSK). Length measurements, vital for the determination of the coordinates, are implemented by means of an eccentrically placed EDM aimed at the omnidirectional reflective prism in the position on the surface. To determine the plummet line coordinates on the surface

¹ Ing. Pavel Černota, Ing. Hana Staňková, Ph.D., VŠB – TU Ostrava, Faculty of Mining and Geology, Institute of Geodesy and Mining Surveying, 17.listopadu 15/2172, 70833 Ostrava-Poruba, Czech Republic, hana.stankova@vsb.cz, pavel.cernota@vsb.cz

² Ing. Silvia Gašincová, Ph.D., Faculty of mining, ecology, process control and geotechnology, Technical university of Košice, Park Komenského 19, 040 01 Košice, Slovak republic, silvia.gasincova@tuke.sk

(at the shaft mouth) the suspension or suspensions for the omnidirectional prism are cast onto the connected horizon. After stabilization of the plummet lines in the vertical, connecting and orientation surveying is repeated onto the connected horizon in a way that the directions and lengths are measured both on the omnidirectional prisms as well as on the basic orientation lines (BOL), whose coordinates may be consequently defined from the read quantities.

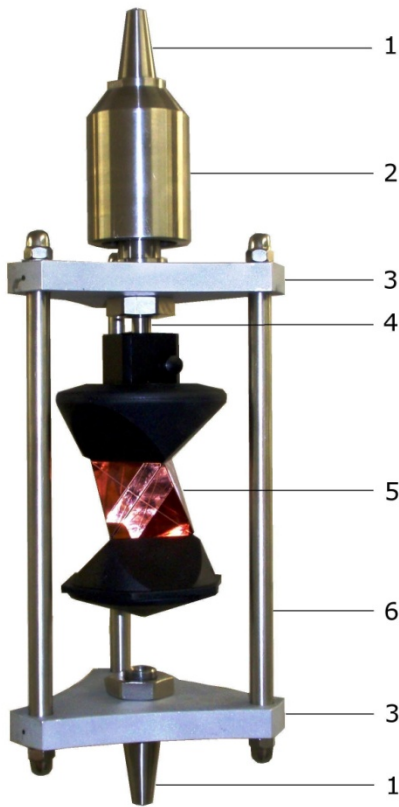

Fig. 1. Hinge for omnidirectional prism.

- 1 – Screw for centric fastening of a steel wire
- 2 – Bush with bearings permitting rotation of the suspension
- 3 – Bearing plate
- 4 – Pin to fix a reflective prism
- 5 – Omnidirectional reflective prism
- 6 – Connecting rods

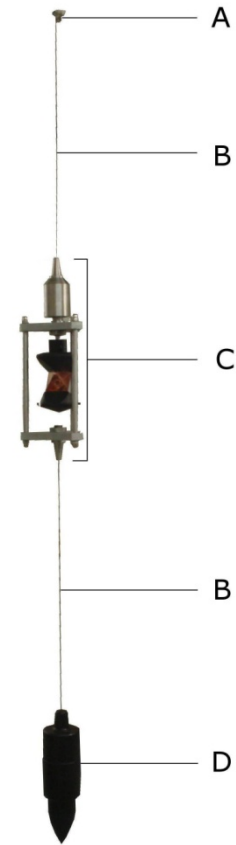

Fig. 2. Hinge for omnidirectional prism with plummet.

- A – Projected point
- B – Steel wire
- C – Suspension (See Fig. 2)
- D – Plumb bob

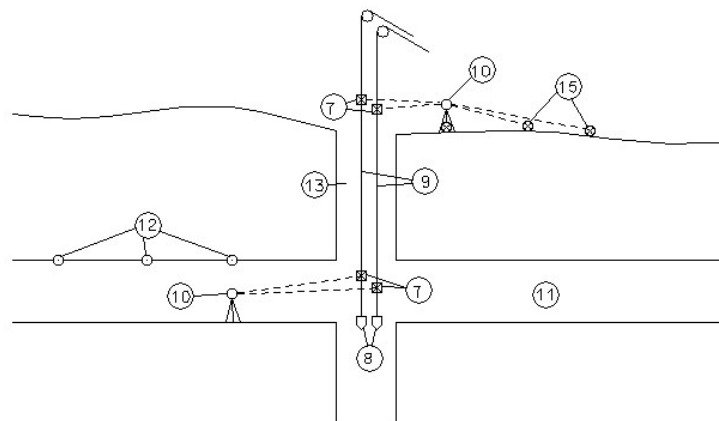

Fig. 3. Connection and Orientation measurements with one shaft and two plummet.

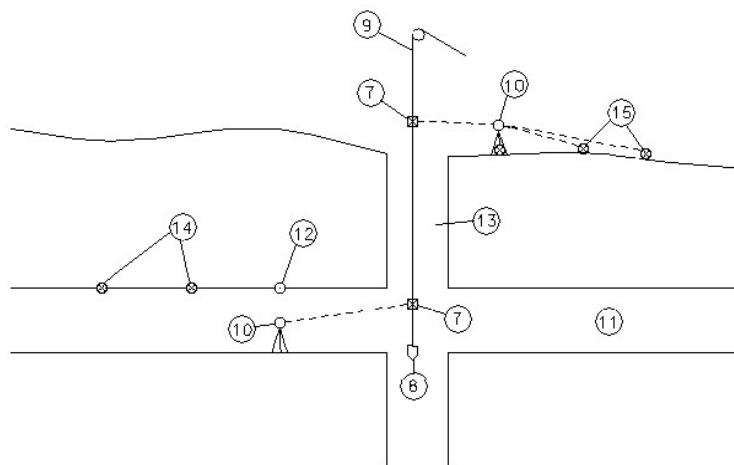

Fig. 4. Connection and Orientation measurements based on the point of the projected one shaft and directionally orientation line by gyrotheodolite.

Figures 3-5 show examples of using different devices at various types of connecting and orientation surveying, where the individual numbers in the figures are to mean:

7. Suspension for coaxial placement of an omnidirectional prism (a-position on the shaft mouth, b-position on the horizon),
8. plummet line,
9. steel wire,
10. electrooptical distance meter,
11. connected horizon,
12. basic orientation line,
13. shaft,
14. gyrotheodolite,
15. known (set) points.

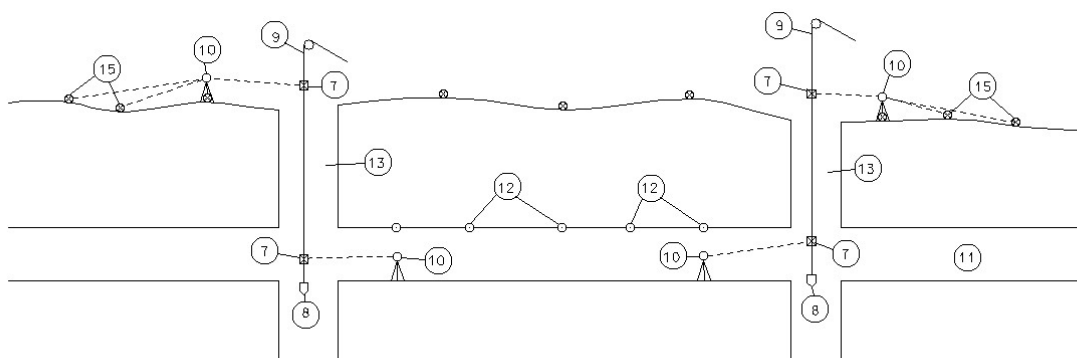

Fig. 5. Connection and Orientation measurements with traverse interposed between points plummeted by two shafts.

Connecting and Orientation measurements within driving the horizon situated in a low depth

Procedure of indirect distance measurements by means of electro-optical distance meter with both connecting and orientation measurements has been verified during driving the collector situated in the center of the town of Ostrava (Fig. 6).

Development of the horizon of driven collector has been done thru three shafts of rectangular cross section up to the depth of 10 m underground, featured with following dimensions: shaft "D" 6.20 x 7.20 m, shaft "E" 6.70 x 4.90 m, and shaft "F" 4.60 x 4.80 m, respectively.

Driving the collector took place in four development headings applying the system „heading – counter heading“ (Fig. 6, where: "D", "E", "F" – foundation pits; V1, V2, V3 – technological drill holes; K7, K20 – collector chamber) in these directions: shaft "F" – chamber K17, shaft "E" – chamber K14, shaft "E" – chamber K12, shaft "D" – chamber K7. Lengths of driven sections were as follows: "D – E" 438 m and "E – F" 276 m. Connecting and orientation measurements during the driving took place in four stages. Any and all surveying works were done by exact measurements. This accuracy is stipulated as per the (Regulation of the Czech Mining Office Board No. 435/1992 of Law Digest).

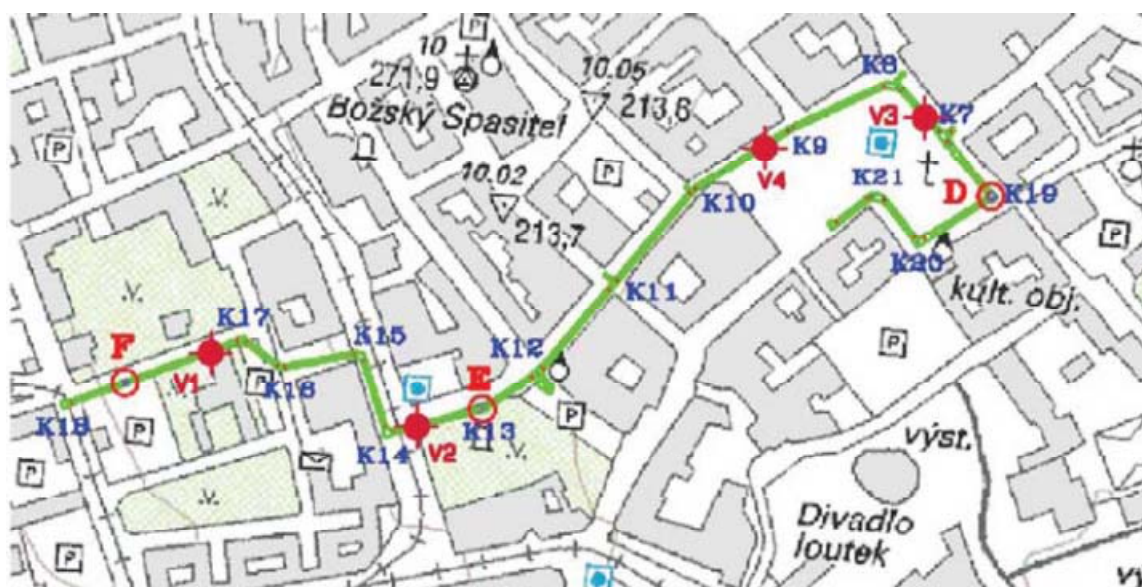

Fig. 6. The utility tunnel route with chambers, construction shafts and technological boreholes (Staňková et al., 2010).

I. Stage

With respect to the above mentioned method of the horizon development (3 shafts) we have to apply method of projecting two plummets thru a single shaft and a line then represented a connecting pattern. Driving direction was set out from the points of setting out network. Holes for plummet suspension were bored into brackets installed at all the shaft mouths. Coordinates of projected abscissa (plummets) were determined in S-JTSK national reference system from the surveying point situated at the shaft, applying the omnidirectional prism coaxially inserted into suspension over the plummet. Plummets in the shaft determined the direction for driving the collector within the time, when the driving direction could be determined directly by the points located in the collector tube itself.

II. Stage

After driving of ca 6 meters of the collector the plummets were connected again to the shaft mouth. With respect to low depth of the underground mining working, ZNL optical centering device made by WILD was applied for projecting the abscissa on the horizon. Universal measuring device has been centered under the hole of one of brackets situated on the shaft mouth, while plummet was hauled down thru the hole of other shaft. Driving direction was transmitted to the collector tube and fixed with a quaternion of points in its axis.

III. Stage

After diving 30 – 40 m it was necessary to put more precisely connecting of the collector at faces, since the lengths of abscissas projected in shafts ("F" – 4.113 m, "E" – 5.814 m, "D" – 6.214 m) did not ensure successful puncture. Detailed connecting and orientation measurements were done after drilling the technological holes Nos. 1, 2, and 3 by below mentioned way. Drill holes were of 0,300 m diameter, sheeted. Connecting on the surface was done such a way, that a single plummet was connected at the shaft mouth. Second point was signaled by the prism located over the drill hole mouth. First point of the abscissa was projected on the horizon by optical centering device and the other applying standard mechanical

projection and using coaxially inserted omnidirectional prism at the drill hole axis. A triplet of previously fixed points situated in the collector vault was surveyed at each shaft from this abscissa (BDL) see Fig. 7, Fig. 8. Thru performing measurements such a way, the lengths of connecting abscissas (shaft – drill hole) carried on the collector horizon enlarged.

Fig. 7 and Fig. 8 means: A – suspension with plummet and omnidirectional prism, B – surveying prism, C – bracket for plummet fixation on the shaft mouth, D – universal measuring device (Leica TC 1700), E – orientation to the points of control network, F – foundation pit, G – technological drill hole, H - collector, 1,2,3 – points for securing the basic directing line.

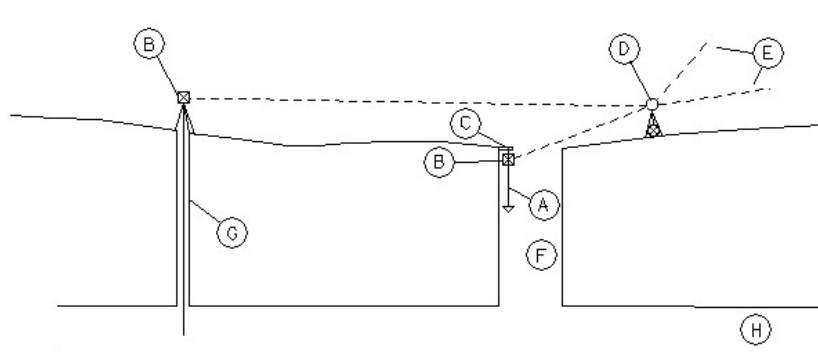

Fig. 7. Connecting on the plummet line on the surface (Staňková et al., 2010).

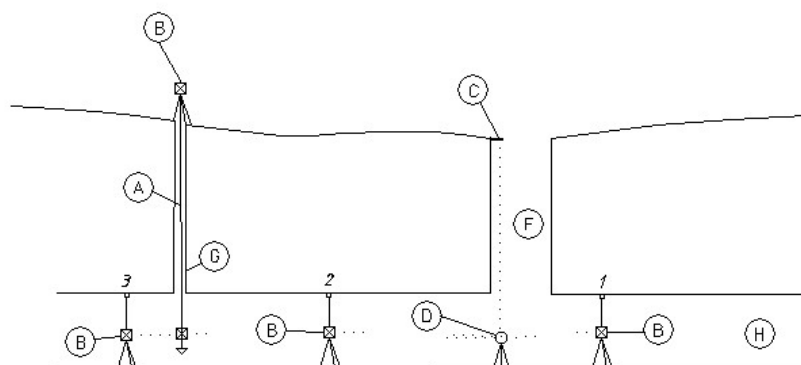

Fig. 8. Connecting on the basic orientation line in the underground (Staňková et al., 2010).

IV. Stage

After puncturing the collector sections among the $F \leftrightarrow E \leftrightarrow D$ shafts, the horizon was finally connected and oriented thru inserted traverse, drawn between points projected by shafts “F” and “D”, again applying omnidirectional prism coaxially inserted into suspension with a plummet. More details as for the collector driving method in the center of the town of Ostrava see in (Staňková et al., 2010).

Conclusion

Indirect measuring of distances with connecting and orientation measurements used to be done the same way like standard measurement of distance using tape with comparing protocol, however, coordinations of projected abscissa end points (plummets), both on the surface and underground, are determined from the surveying point applying the electro-optical distance meter with utilization of omnidirectional prism inserted coaxially into the suspension over the plummet. Application of the electro-optical distance meter lowers the influence of systematic errors with direct measuring of distances using tape with comparing protocol, as well as physical and geometrical reductions may be put directly into distance meter software. Resulting distances are corrected by influence of the above mentioned errors.

Procedure of indirect measuring the distances by means of electro-optical distance meter upon connecting and orientation measurements was verified in practice within driving the collector situated in the center of the town of Ostrava. Based on this practical verification the device for indirect measuring of distances for connecting and orientation measurements has been entered by the Industrial Property Office of the Czech Republic as the utility model under No. CZ 21047 U1. Procedure of indirect measuring the distances connecting and orientation measurements was submitted to the Industrial Property Office of the Czech Republic as a patent – invention application No. PV 2010-165.

Device may be applied for connecting and orientation measurements within mine surveying, underground civil engineering, activities run as mining ones as per (Neset, 1967), and speleology. Design of the device enables, thanks to bearings located in suspension bushing also inserting standard unidirectional surveying prism (possibility of suspension rotation in all directions). Among advantages of this distance measurement procedure with connecting and orientation measurements applying this device are listed as follows: safety and work organization, time modesty, distance measurement accuracy, direct entering the correction from the impact of systematic errors, process economy, and operability of this solution.

References

- [1] Neset, K.: Mine Surveying (Důlní měřictví II), *SNTL, 1967*
- [2] Regulation of the Czech Mining Office Board No. 435/1992 of Law Digest: On Mine Surveying Documentation for Mining Activities and Other Activities Run by Mining Way, in wording of later regulations (O důlně měřické dokumentaci při hornických činnostech a některých činnostech prováděných hornickým způsobem, ve znění pozdějších předpisů)
- [3] Staňková, H., Černota, P., Pospíšil, J.: Connecting and Orientation Measurements within Driving the Collector Situated in the Centre of the Town of Ostrava (Připojovací a usměrňovací měření při ražbě kolektoru v centru města Ostravy), *Tunel, 19. annual volume – No.1/2010, p. 50-53, ISSN 1211-0728.*