

Time-lapse monitoring of hard-rocks properties in the vicinity of underground excavation

Jaroslav Bárta¹, Dušan Dostál¹, Jaroslav Jirků², Václav Kopecký³, Lubomír Slavík³ and Jan Vilhelm²

Studying the behavior of the rock mass is essential for developing a geophysical monitoring system, which allows continuous time-lapse monitoring of the state of the rocks environment. For example, rock mass monitoring might be a crucial part of a system for storing dangerous, especially nuclear waste in a geological environment. The goal of this project is developing a working system for long-term time-lapse monitoring of a geological environment using non-destructive geophysical techniques. The monitoring system works with geoelectrical and seismic properties of the hard-rocks environment. The system carries out 4D monitoring of the rock properties behavior in the close vicinity of an underground excavation. For the initial experimental measurements, two geophysical methods were chosen - electrical resistive tomography (ERT) and ultrasonic microseismic. The ERT method uses a set of 48 stainless electrodes 20 cm apart (9.4 m length of the profile in total) and the frequency of the measurements is six hours (i.e., four measurements per day). Currently the seismic uses frequency of five minutes between gathering one seismic record. Attention is paid to the behavior of a significant fracture located in the middle of the measuring system. The monitoring device collects data that are being sent via the LAN connection to the project members' computers.

Key words: geophysical monitoring, electrical resistivity tomography, seismic time-of-flight measurement, underground excavation, fracture systems

Introduction

A part of the underground excavation's risk management is also the monitoring of the geological environment in the close vicinity of the excavation as described in the Pamukcu (2015) for instance. One can use some of the geophysical techniques as reviewed in the Spillmann et al. (2010). Currently, the main way of the monitoring of the rock mass' behavior in the vicinity of the excavation is based mainly on measuring the deformations in time and describing the consequences of such deformations. These deformations are very frequent mainly on the weakened geological structures; typically fracture zones or tectonic lines. One can measure the rate of relative shift of two rock blocks, split by a disturbance. Such disturbance is very often connected with so-called seismoacoustic emission that is generated during the brittle rock's disturbance formation.

Let's assume a rock mass' environment in which we do not expect any sudden changes in the state of stress that could lead to new disturbances occurrence. For monitoring of such massif (particularly the vicinity of the underground excavation), one can use the seismic methods, namely the tomographical approach. Then we can measure the seismic waves' properties (seismic velocity or changes in the seismic amplitudes) on the long-term basis during their transmission through a rock massif. Repeated measurements, or monitoring, using the electrical resistivity tomography methods, can be a useful way of controlling the seismic measurements results as the ERT should sensitively react to the rock mass' changes caused by changing groundwater's saturation (Loke et al., 2013; Donno and Cardarelli, 2014).

Original plans of such monitoring methodology are connected with previous works carried out since 2003 in the Bedřichov gallery that mainly works as a water conduit from the Josefův Důl dam to the Bedřichov water plant (Liberec region). The gallery was drilled out in 1980th in the granite rocks.

Monitoring of arising processes in the rock massif, connected with changes in the state of stress or production of new microcracks, can be viably carried out via time-lapse seismic ultrasonic tomography or regular 4D monitoring of the apparent resistivities. Regarding the effect of the load distribution caused by the excavation's shape, one can also use mathematics modeling, as described in the Yang et al. (2016) paper.

Changing the state of stress in the rock mass' microcracks system is directly connected to the elastic waves' propagation. Similarly, there is a well-known connection between apparent resistivity and the state of the manner of rock. However, using both methods together for predicting future behavior of a rock massif has not been presented yet. Using the ERT methodology (Friedel, 2003) in the unfavorable conditions of higher resistivities

¹ Jaroslav Bárta, Dušan Dostál, G IMPULS Praha, Přístavní 24, 170 00 Prague, Czech Republic, barta@gimpuls.cz, dostal@gimpuls.cz

² Jaroslav Jirků, Jan Vilhelm, Charles University in Prague, Faculty of Science, Institute of Hydrogeology, Engineering Geology and Applied Geophysics, Albertov 6, 128 43 Prague, Czech Republic, jirku4@natur.cuni.cz, vilhelm@natur.cuni.cz

³ Václav Kopecký, Lubomír Slavík, Technical University of Liberec, Faculty of Mechatronics, Informatics and Interdisciplinary Studies, Institute of Systems Control and Reliability Management, Studentská 2, Liberec, Czech Republic, vaclav.kopecky@tul.cz, lubomir.slavik@tul.cz

(around ten thousand Ωm) and sudden contrast in them has brought a new conclusion that such methodology can be reliably used. In such conditions, the only main parameter influencing the electrical resistivity is the content of the groundwater and its mineralization in the microcracks system. The developed methodology can be used for example in monitoring projects of underground storages. The long-term monitoring of water content is important even in the case of radioactive waste repository projects (e.g., Bartko et al., 2014). One of the new approaches we have brought is also the methodology of the seismic tomography measurements, namely the way of seismic waves' excitation and registration.

During our multi year's research in the Bedřichov gallery, we found out that one can see minor changes in the mechanical and hydrogeological parameters in the gathered data. Such anomalies are crucial for better understanding of the processes in a rock massif, and therefore their 4D variations should be captured by the time-lapse monitoring. We incorporated this requirement into our original measuring system. It allows storing of the data and can send them furtherly via LAN connection for further interpretation or automatical warning on the processes occurring in the relevant bodies.

This research proceeded mainly due to the TA03020408 grant, provided by the Technology Agency of the Czech Republic, which was launched in 2013 and was successfully completed in 2016.

Material and Methods

The SGI 1 geophysical monitoring system in the Bedřichov tunnel (Jizera Mts.) is the main deliverable of our research. It allows repeated measurements of apparent resistivities via a system of up to forty-eight stainless electrodes placed in-line on the gallery wall. Such measurements allow continuous monitoring of a rock massif. At our field base, also seismic piezo sensors (geophones) and the transmitter of the elastic waves (also working on the piezo effect phenomenon) are placed. These allow monitoring of the massif according to the propagation of the elastic waves through the rock. Currently, the SGI 1 system works with three receiving and one transmitting sensor.

Another potential ability of the system is to monitor the electrochemical processes in the massif, mainly via the time-lapse time-domain induced polarization (IP) measurements. Another parameter that can be observed is the seismicity at high frequencies, i.e., natural processes that occur without any artificially excited elastic waves. The scheme of the SGI 1 system is shown in the Fig. 1.

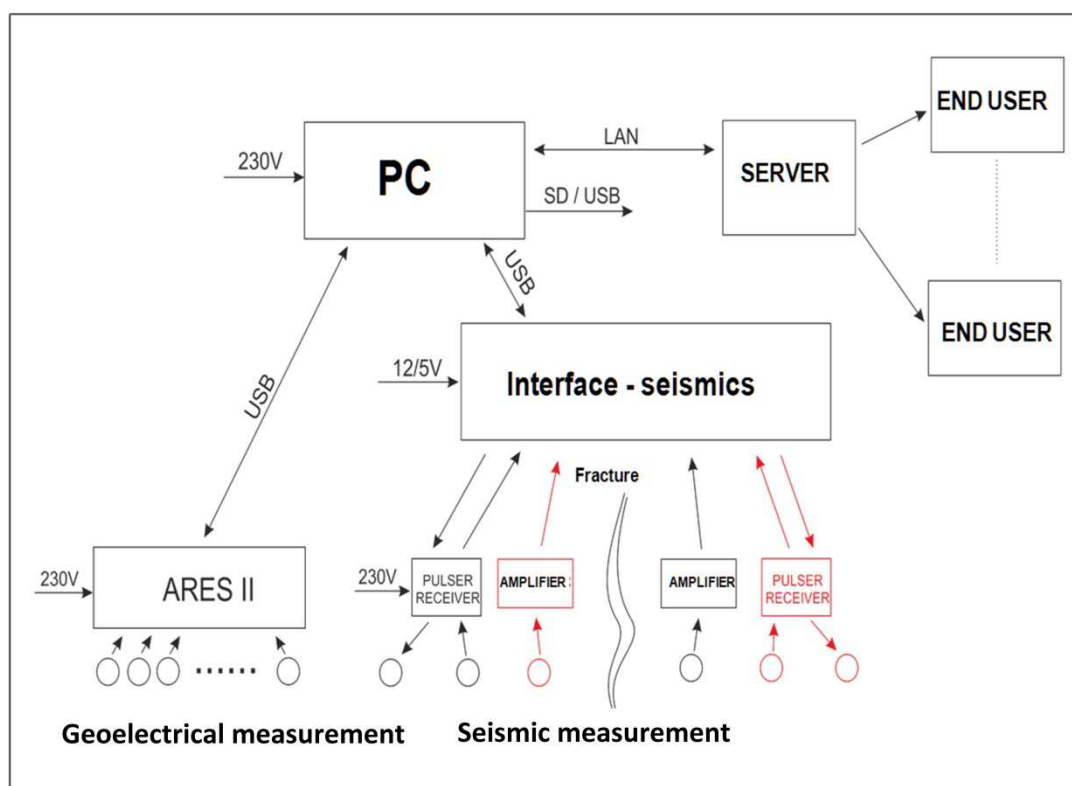

Fig. 1. Current scheme of the SGI 1 system.

We use the Schneider Thalassa PLM switchboard with transparent door housing for the controlling electronics' protection. The whole system is supervised by the Advantech ARK 1503 industrial PC. There are

also another components in the switchboard, namely – power supply, high-voltage protection, seismic instrument's electronics and the Olympus 5077PR pulser-receiver.

For the ERT and IP measurements, the ARES II. instrument by the GF Instruments company was employed. The manufacturer changed the firmware for us so one can send the data remotely via RS232 socket. This connection allows us to send the data to the FTP server or the external computer. In Fig. 2 one can see the whole system in the Bedřichov gallery together with the crossing tectonic fracture zone going across the geophysical layouts.

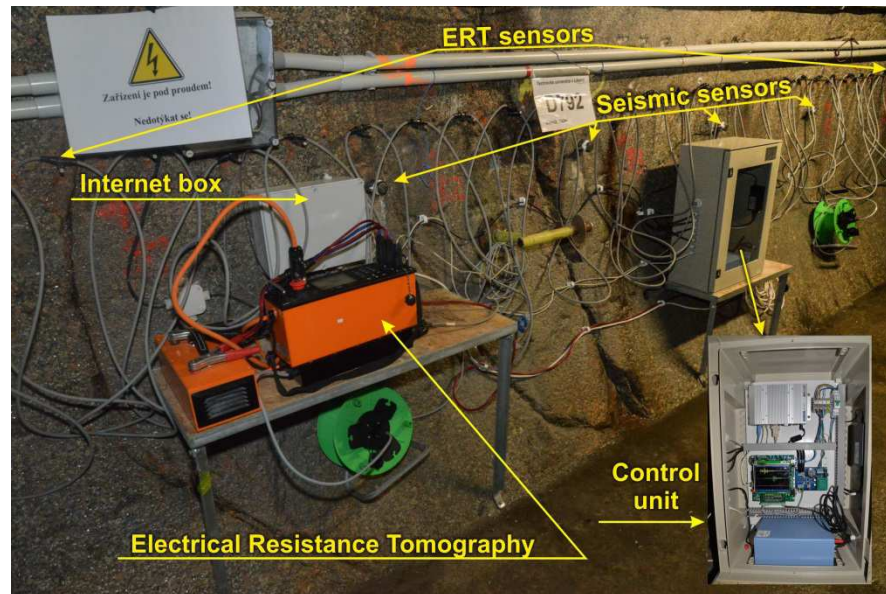

Fig. 2. The SGI 1 system in the Bedřichov tunnel.

The Bedřichov Tunnel Experimental Site

The Bedřichov gallery connects the Josefův Důl dam with the Bedřichov water plant in the valley (Fig. 3). The city of Bedřichov is located in the northern part of the Czech Republic, close to the city of Liberec. From the geological point of view, the site consists of the granite that belongs to so-called Liberec petrographic unit.

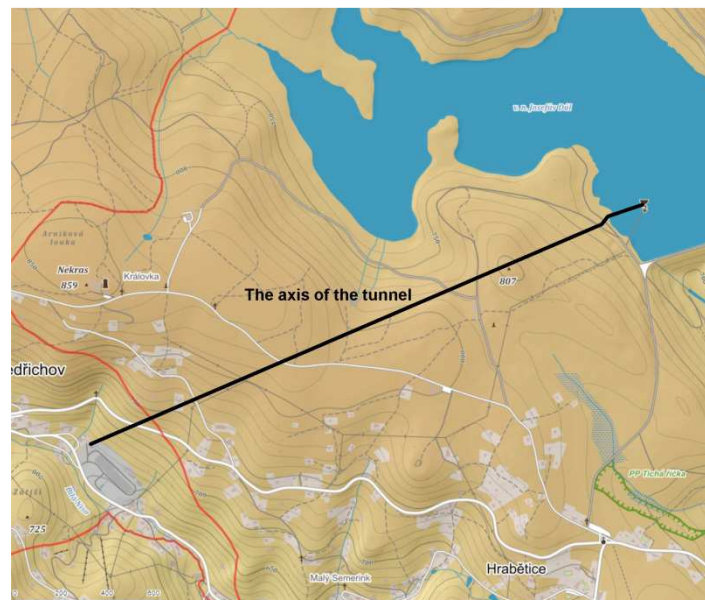

Fig. 3. Location of the Bedřichov tunnel with its ending in the form of a vertical shaft into the dam.

This type of rock is often used as a building material and very often reaches the parameters of decorative stone in terms of quality. Currently, the Liberec granite is being extracted at the nearby Hraničná and Ruprechtice quarries. These quarries lie approximately ten kilometers from the Bedřichov gallery and are very good surface analogs for our tunnel's measurements. The potable water from the Josefův Důl dam flows to

Bedřichov via steel pipe that lies on the side of the excavated Bedřichov gallery. The other side of the tunnel's wall is being extensively used for many scientific research projects (geomechanics, thermometry or hydrogeology). Two hydroelectric power plants are placed at the entrance of the tunnel. These power plants are sources of a DC noise in the form of so-called stray currents. During all geophysical measurements, we have to deal with these currents. In any case, research on this topic may be another interesting chapter in learning of the potential effects of the stray currents on the underground bodies.

In 2003, vast geophysical research in the tunnel had started, mainly with emphasize to the ERT method and hammer seismic. The experience with previous measurements that were carried out with frequencies of roughly several months led us to the idea of continuous time-lapse monitoring in the regular short frequency of measurements. Also, a requirement for the data to be remotely sent via the LAN network to the researchers was set. The 2003 – 2012 research spans proved that there are remarkable ongoing processes (according to the ERT) in the massif.

There are several remarkable experimental sites in the gallery that are being used for the purposes of the geophysical research. For the research presented here, we picked the point of 792 m from the entrance to the tunnel. This place is the main test site for the TA03020408 project, and the SGI 1 system is placed and tested here.

Results

The results of the measurements of this research project are based on the previous stages of the research works in the tunnel. Details on related issues can be found for instance in Vilhelm et al. (2013), Jirků and Bárta (2014) or Bárta and Jirků (2011). For the information regarding the issues of the microseismic measurements in hard rocks, we refer mainly to Petružálek et al. (2013). We would also like to refer to the works of Barton (2006) and Daily et al. (2005) as sources of information on the physical properties of the hard rocks and the connection of these issues with the practical fields of tunneling for instance. One part of the project's goals also includes particular technically oriented conclusions in the form of a certified methodology and utility model.

In the Fig. 4a (P-waves velocity) and 4b (S-wave velocity), one can see the examples of the seismic measurements from the regular time-lapse monitoring in the Bedřichov gallery. The crucial conclusion is the fluctuation of the seismic velocities magnitude at the monitoring base, which is almost negligible (the records remain almost unchanged). Therefore, we can state that any change in the velocities would have to be caused only by the occurrence of a new microcracks system. There are three seismic records, which equals to three seismic receivers at the distances of one, two and three meters from the transmitter.

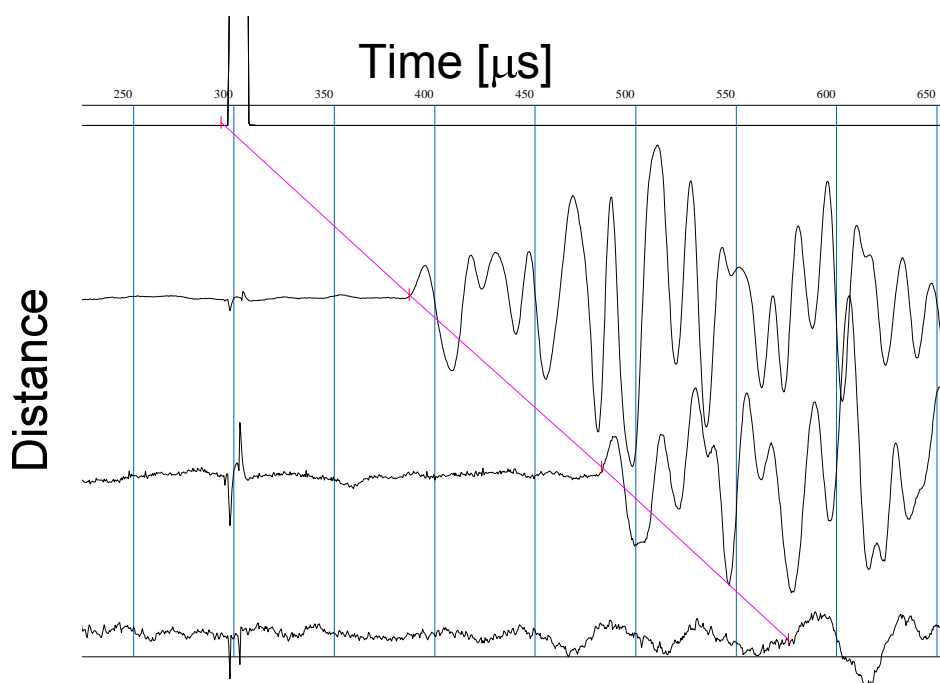

Fig. 4a. P-waves velocity determination on the seismogram. The straight blue line represents a time-distance curve of the P-wave.

The overall picture taken from the data gained by the monitoring (also with respect to the previous phases of the research) can be summed up in several conclusions. The crystalline rock massif in the gallery is characterized by the P-wave velocities of roughly 5250 m/s. The S-waves velocities oscillated mainly around

the values of approximately 3000 m/s. The mean value of the Poisson ratio from the earlier stages of the geophysical works was calculated to approximately 0.25. The values of the seismic velocities are more or less equal to the overall technical experience for the HQ granites in an unloaded state, i.e., measurements on the horizontal ground surface. Regarding the value of the Poisson ratio, we consider it slightly surprising as one might guess the value should be lower for the intact hard-rocks environment. The third seismic channel (more distant from seismic source) is set over a small fracture and therefore is attenuated.

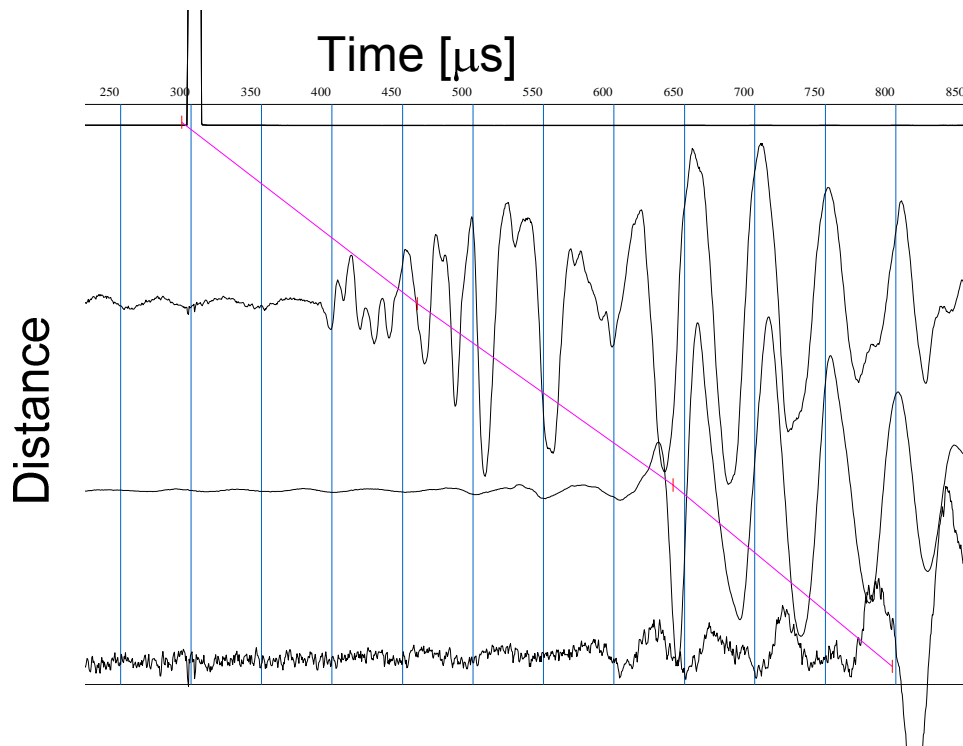

Fig. 4b. S-waves velocity determination on the seismogram. The straight blue line represents a time-distance curve of the S-wave.

The values of apparent resistivity gained from our measurements typically vary between first hundreds to tens of thousands Ωm . The minimal values can be interpreted as crushed, heavily weathered or water-saturated rocks in the tunnel. The maximal values equal to the HQ granite parts with the almost complete absence of any fracturing and groundwater. However, the crucial finding of our measurements is the fact that there are slight changes of the massif in time (with respect to the ERT data). We prove this in the Fig. 5 when one can see several selected cross-sections of apparent resistivity from the 792 field base in the gallery. We selected cross-sections with approximately one-month frequency. There are many inversion codes for the original resistivity data using the layered model approach, namely Kohlbeck and Mawlood (2009), Johansen (1977), Zohdy (1989), Koefoed (1979) or Basokur (1990). We used standard approach using the Res2Dinv programme (Loke, 2001), which produces the 2D inverted distribution of apparent resistivities. The mean error or repeated measurements was surprisingly low in this case – during the testing phases we were able to go down to less than one percent. Apparently, there can be a huge influence of the unexpected events, say in the form of the parasitic currents for instance. However, the quality of the data is protected by the averaging of them as the instrument measures several values at one point, and the standard deviation cannot be higher than five percent. The Fig. 5 shows minor processes occurring in the cross-sections; however, we still do consider them distinctive in time. We believe that these anomalies are caused by changing moisture content in the rock environment and possibly changing mineralization of the groundwater too. We believe that the system around the fracture can be described not as a one huge isolated “slot” but as a complex system of tiny microfractures, which are wet and mutually connected. This system can drain the main fracture zone. It becomes dry then and is characterized by extremely high resistivities as shown by blue colors in the Fig. 5. We can state, that specified macroscopic fracture on a rock face is an only first indication of more complex system and intricate metabolism under the surface.

The results in the Fig. 5 are very illustrative; however, the statistical processing of measured data can be very useful too. It means that measured values at particular points can be compared in time. Selected points are shown in the Fig. 6. This picture clearly demonstrates varying values of the resistivity in time from several places of the cross-section. The depth of the points varies between 0.2 to 1 m. The gradient of the values goes up to thousands Ωm at some places.

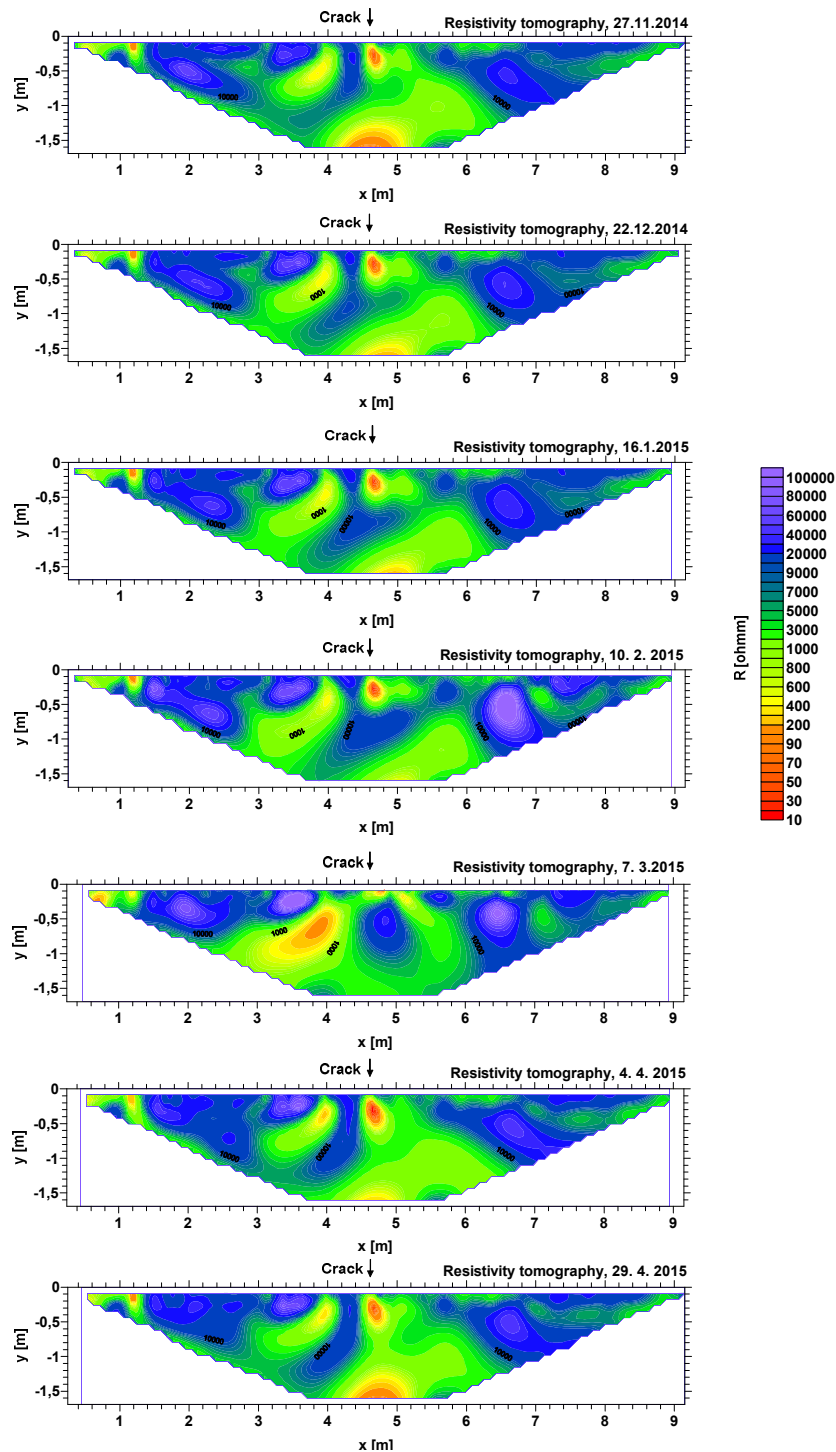

Fig. 5. Cross-sections of apparent resistivity from the 792 field base, by the SGI 1 system.

Discussion and Conclusions

Conclusions gathered from this research project helped in better understanding the processes in the granite massif from the geophysical methods' point of view. Some conclusions, as the complex behavior of the hydrogeological processes in the vicinity of a fracture (Fig. 5), detected by the ERT method, seem to be a huge complement to the classic macroscopic approaches of a geologist. The microcracks system shows clear changes in the apparent resistivities. The highly disrupted zone of the cross-section shows the biggest changes. In the Fig. 5, one can clearly distinguish fractured tectonic zone in the form of a shallow quasi-vertical high-resistive body. Apparently, observed changes are probably mostly related to fluctuating water content and changes in the mineralization of the groundwater in the fractures.

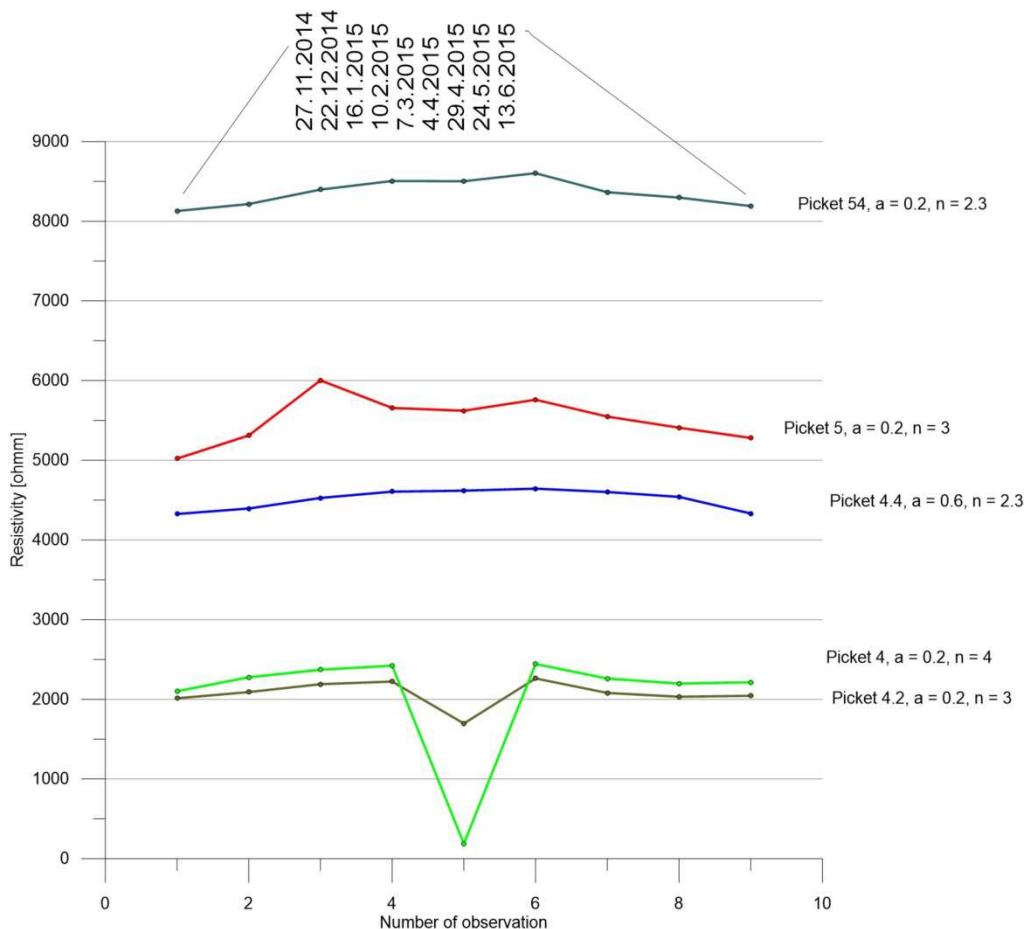

Fig. 6. Particular points of the cross-section – fluctuating resistivity in time.

Regarding seismic measurements, we were not able to see any remarkable changes in the seismic records. With respect to the high precision of such measurements, we believe that this proves very stable geological environment from the mechanical point of view. Any remarkable changes in the state of stress should be measurable via our system.

The SGI 1 monitoring system proved to work well during the initial periods and is going to be adjusted in the near future. Our system can monitor processes around major mining works, for instance in case of deep geological repositories of dangerous waste.

Acknowledgements: The research team would like to thank the Technology Agency of the Czech Republic for the financial support granted for addressing the aforementioned issues under the project TA 03020408.

References

- Barton N.: Rock quality, seismic velocity, attenuation and anisotropy. *Taylor and Francis Group, London, 2006.*
 Bárta J., Jirků J.: Resistivity tomography in studying the granite massif in the Bedřichov gallery (the Jizerské hory Mountains). *Findings and conclusions gained so far from the measured data. EGRSE 2, ISSN 1803-1447, 2011.*
 Basokur A.T.: Microcomputer program for the direct interpretation of resistivity sounding data. *Computers & Geosciences 16(4), 587–601, 1990.*

- Bartko M., Baláž J., Pandula B.: Slovak Republic Repository of Radioactive Waste. *Metalurgija*, 53, 105-108, 2014.
- Daily W., Ramirez A., Binley A.M., Labrecque D.: Electrical resistance tomography: theory and practice. In D.K. Butler (ed.), *Near surface geophysics. 13 edn, Investigations in geophysics, Society of Exploration Geophysicists*, pp. 525-550, 2005.
- Donno G.D., Cardarelli E.: 3D complex resistivity tomography on cylindrical models using EIDORS. *Near Surface Geophysics*, 12, 587-598, 2014.
- Friedel S.: Resolution, stability and efficiency of resistivity tomography estimated from a generalized inverse approach. *Geophys. J. Int.* 153, 305-316, 2003.
- Jirků J., Bárta J.: Monitoring of joint systems time-lapse behavior via ERT. Environmental and Engineering Geophysical Society, *SAGEEP 2014, Boston*, 2014.
- Johansen H.K.: A man/computer interpretation system for resistivity soundings over horizontally stratified Earth. *Geophysical Prospecting* 25, 667-691, 1977.
- Koefoed O.: Resistivity Sounding Measurements, Ser. Methods in Geochemistry and Geophysics 14A, Geosounding Principles 1. Elsevier, *Amsterdam-Oxford-NewYork*, 276 pp, 1979.
- Kohlbeck F., Mawlood D.: Computer program to calculate resistivities and layer thicknesses from Schlumberger soundings at the surface, at lake bottom and with two electrodes down in the subsurface. *Computers & Geosciences* 35, 1748-1751, 2009.
- Loke M.H., Chambers J.E., Rucker D.F., Kuras O., Wilkinson P.B.: Recent developments in the direct-current geoelectrical imaging method. *Journal of Applied Geophysics* 95, 135-156, 2013.
- Loke M.H.: Tutorial: 2-D and 3-D electrical imaging surveys. 2001.
- Pamukcu C.: Analysis and management of risks experienced in tunnel construction. *Acta Montanistica Slovaca* 20, 271-281, 2015.
- Petružálek M., Vilhelm J., Rudajev V., Lokajíček T., Svitek T.: Determination of the anisotropy of elastic waves monitored by a sparse sensor network. *International Journal of Rock Mechanics and Mining Sciences*, 60, 208-216, 2013.
- Spillmann T., Blüming P., Manukyan E., Marelli S., Maurer H.R., Green A.G.: Geophysics applied to nuclear waste disposal investigations in Switzerland. *First Break* 28,39-50, 2010.
- Vilhelm J., Rudajev V., Lokajíček T., Živor R.: Velocity dispersion in fractured rocks in a wide frequency range. *Journal of Applied Geophysics*, 90, 138-146, 2013.
- Yang J.X., Liu C.Y., Yu B.: Effects of load distribution exerting on coal pillars on the stress and energy distribution of the floor strata. *Acta Montanistica Slovaca* 21, 102-112, 2016.
- Zohdy A.A.R.: A new method for the automatic interpretation of Schlumberger and Wenner sounding curves. *Geophysics* 54(2), 245-253, 1989.