

The Model of Direct Dumping Technology Implementation for Open Pit Coal Mining by High Benches

Maxim Tyulenev¹, Sergey Markov², Michal Cehlar³, Sergey Zhironkin⁴ and Magerram Gasanov⁵

The article describes a problem of coal open pit sides designing with combined mining method (transport and direct dumping by high benches). The architecture of open pit sides implies solving the problems of decreasing coal open pits land capacity, application of direct dumping technology with internal dumping which increases coal mining economic and environmental efficiency. The main criteria defining the architecture of quarry sides for flat coal seams strata open-pit mining are general slope angle of internal multi-tier dump, the height of transport and direct dumping sub benches on the face side, the number of tiers and their height, the width of the berms on the dump site. The increase of benches height at open pits developing deposits with flat coal seams entails the use of a combined technology: transport and direct dumping to develop the upper and lower sub benches respectively. Therefore, it is necessary to advance methodology for calculating the parameters and indices of direct dumping technological schemes and find ways to increase the capacity of internal dumps and provide safety for open pit mining operations. As a result of research, the model of direct dumping technology implementation for open pits mining coal by high benches is presented in the article. The research was based on the data from Southern Kuzbass (Kemerovo region, Russia) coal deposits being developed by large open pits.

Key words: design of quarry sides, open pit mine, direct dumping, high bench, dragline, internal dumps

Introduction

At present, in Russia, in particular in Kuzbass (the main coal-mining region located in Western Siberia), large open pits develop coal deposits with flat seams (Agafonov, 2017; Gvozdkova, 2017; Tyurin, 2017). There is a trend towards increasing the height of the benches (so-called "high benches") followed by their development with combined transport and direct dumping technology by two sub-benches. The upper sub bench is worked out by transport technology with loading rock for motor transport, the lower one is by direct dumping, with rock transfer to internal dumps by a dragline (Alarie, 2002).

This allows, firstly, using equipment with a large unit capacity (dump trucks with carrying capacity up to 460 tons, draglines with a bucket capacity of more than 40 m³). Secondly, the growth of annual coal production in Kuzbass from 100 to 220 million tons over the past decade has been accompanied by an increase in the number of sections, from 42 to 66. This means the need to improve open coal mining technologies that allow minimising the use of land resources and, thus, reduces withdrawal of agricultural land from farming and allocation of dust from the dumps (Cehlar, 2017).

In this sense, direct dumping technologies at open coal pits, tending to horizontal and flat coal seams extraction, are preferable to transport ones especially considering innovations in high benches drilling and blasting (Hrehová, 2012). However, it is critically important for direct dumping effective application that as the number of dump tiers placed inside open and the volumes of overburden piled in them increase, the requirements to the accuracy of calculating the main parameters face and dumping sides are repeatedly increased. This is stimulated mainly by the requirements for the stability of internal dumps in order to avoid landslides (Tyulenev, 2018).

Thus the increase of the benches height changes the profile of open pit and raises the issues of architecting its face and dump sides. In this regard, three key tasks of open pit sides architecting are considered to be relevant:

1. Determination of the optimal height of transport and direct dumping components of the high bench, which makes it possible to use draglines with maximum effectiveness to move the overburden into internal dumps.
2. The choice of the best direct dumping scheme with different heights of direct sub bench, which makes it possible to fully use the capacity of internal dumps.
3. Determination of general angle of the slope of the internal dump, guaranteeing the absence of landslides if the technology of its backfilling is observed.

¹ Maxim Tyulenev, Kuzbass State Technical University, Kemerovo, 650000, Vesennaya Street, 28, Russia, tma.geolog@kuzstu.ru

² Sergey Markov, Kuzbass State Technical University, Kemerovo, 650000, Vesennaya Street, 28, Russia, markovso@kuzstu.ru

³ Michal Cehlar, Technical University of Košice, 042 00 Letná, 9, Košice, Slovakia, michal.cehlar@tuke.sk

⁴ Sergey Zhironkin, Siberian Federal University, 79 Svobodny pr., 660041 Krasnoyarsk, Russia, National Research Tomsk Polytechnic University, Tomsk, 634050, Lenin Avenue 30, Russia, zhironkin@inbox.ru

⁵ Magerram Gasanov, National Research Tomsk Polytechnic University, Tomsk, 634050, Lenin Avenue 30, Russia, hursud1@yandex.ru

Materials and Methods

Analysis of the state of mining at Southern Kuzbass open pits showed that at present, using direct dumping technology, strata of two coal seams with 49-52 m of the total thickness of rock formation is being worked out. The overburden is piled into three-tier dumps of 73-78 m high. The cost of the direct dumping of overburden is 30-40 % lower than the transport cost. In addition, there is an excess in the speed of the direct dumping front over the transport one, which leads to a decrease in the volumes of overburden rock developed by direct dumping.

Further, the potential capacity of the internal dump is underused, which can be judged by the ratio of the actual heights of dumps and allowed by the dump slope stability condition (110-150 m).

Considering the above, in order to reduce the cost of overburden removing from the whole open pit, it seems appropriate to partially redistribute the rock volumes between the transport and direct dumping technologies by increasing the volumes of rock placed in the internal dumps. To verify the effectiveness of this proposal, it is necessary to solve a number of technological and technical-and-economic tasks related to ensuring the reception of additional overburden by internal dumps and to define the economically acceptable height of the cut rock layer. When solving these tasks, the conditions for maintaining the achieved indicators of mining operations intensification and reducing the cost of overburden should be met. In this context, the use of high benches allows optimising the parameters of open pit mining of coal using direct dumping technology.

During the period of the 1960s-70s in the former USSR, the areas and boundaries of direct dumping implementation were significantly expanded, thanks to an increase in the height of the rock benches worked out by direct dumping technology, according to the condition of economic efficiency. In addition, at present, combined transport and direct dumping methods of overburden removing are widely used at Kuzbass open pits. Obviously, the minimum costs for the quarry development can only be achieved by direct dumping technology, since the cost of 1 m³ of overburden for transport technology is almost constant, and the cost of 1 m³ of overburden for direct dumping varies depending on the thickness of the overburden, which determines the re-excitation rate. This provision is taken into account in this article.

The task to optimise the height of the bench for direct dumping which influences on the whole architecture of open pit sides is very important because the technology with rock transfer by dragline directly into the dump has a substantially lower cost of processing of 1 m³ of overburden (Cehlár, 2007; Demirel, 2011; Týnková, 2016; Vukotic, 2013). The solution to this problem involves drawing a number of direct dumping schemes of excavation with different heights of dragline sub bench (Karpuz, 1990). Therefore, an appropriate methodological approach to the solution of the problem is necessary.

At present, the researchers, defining the parameters of mining technological processes use grapho-analytical modelling with sufficient confidence (Baafi, 1997; Erdem, 1998; Katsubin, 2018; Malli 2015; Markov, 2017; Martyanov, 2018; Mirabediny, 1998; Prakash, 2013). Therefore, in this article, we present an ideal grapho-analytical model for high bench development by two sub benches (transport and direct dumping) to achieve the aim of parameterisation.

Theoretical provisions of a grapho-analytical model for high bench working by a combined method are given below.

Grapho-analytical model of direct dumping excavation schemes is acceptable for their use in any conditions of coal seams occurrence. Based on the development of the theory of blasting downhole charges and its experimental verification, a computational method was developed for determining the parameters of the collapse of overburden benches with direct dumping technology, which applies to the development by high benches (Martyanov, 2018). In connection with the complication of direct dumping excavation schemes, some authors determined the rational length of the mining front, organising equipment operation for the interconnection of overburden and coal mining operations and its influence on the mining schedule (Tyulenev, 2017; Gvozdikova, 2017). In particular, the following methods of increasing the capacity of the internal dump for direct dumping technology were considered:

- increase the number of tiers of overburden dump;
- an additional charge of the coal seam;
- reduction of the width of the stope, when due to more complete use of the unloading parameter of the excavator, it is possible to put a larger volume of overburden rock in the dump;
- the curvature of mining front works to increase the length of the dump front and, therefore, to increase the capacity of dump;
- development of overburden stope with the shift of dragline's axis in a plan, which allows, as it were, to increase the size of the dragline unloading parameter and, consequently, the dump capacity.

The grapho-analytical model considered in the article implies that the additional charge of the coal seam is usually used in simple excavation schemes, but at the same time, the coal losses increase. This method is not spread in Kuzbass open pit mines due to significant loss of high-quality coal.

Reducing the width of the stope is usually recommended for local mining areas along the front of work with increased overburden thickness. Therefore, this method cannot be applied in the geological conditions considered in the article, characterised by sustained overburden thickness.

The curvature of the work front changes the capacity of the internal dumps, especially with a small radius of curvature, but this method can be applied with relatively small fluctuations in overburden thickness and long quarry fields. In the conditions of the combined technology (transport and direct dumping) with significant dip angles of coal seams suite, this method has very limited application.

The shift of dragline's axis is widely used in the quarries of Russia to increase the capacity of the second tier of the dump. Therefore, this method is used in the study, reflected in this article, devoted to the design of excavation schemes.

When analysing the position of surface mining at open pit mines of Kuzbass, it was concluded that at present mainly three-tier dumps are piled. To accommodate an additional volume of overburden rock in the internal dump, the piling of dumps with a number of tiers of more than three is needed. The real question is about the number of tiers: four, five or more.

The Kuzbass coal open pit mines have experience in piling four-tier dumps, and it has shown a certain complication in the organisation of work of draglines on the dump and an increase in the total re-excavation rate due to the moving of additional rock volumes during its secondary displacement. When dumping five-tier dumps, a significant increase in the total re-excavation rate and complication of the organisation of draglines' work on the dump are expected.

Considering above-mentioned, we define the main part of a grapho-analytical model for high bench working by a combined method as it is given in Figure 1. The initial position of the model consists of two elements: the face and the dump sides.

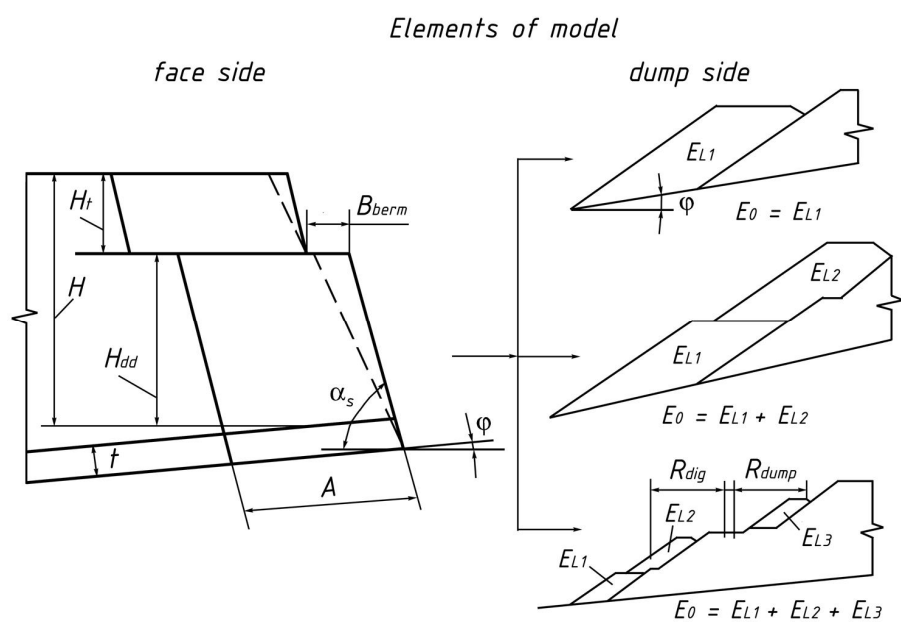

Terms and Conditions

$$H = H_t + H_{dd}; \begin{cases} H = \text{const}; H_t \text{ and } H_{dd} - \text{variables}; \\ H_t \neq 0; H_{dd} \neq 0 \end{cases}$$

$$\begin{cases} H_{\max} = \frac{E_0}{A \times K_d}; H_{\min}^t = 5 \text{ m}; H_{\min}^{dd} = 10 \text{ m}; H_{\min} = 15 \text{ m} \\ H_{\max}^{dd} = H_{\max} - H_{\min}^t; H_{\max}^t = H_{\max} - H_{\max}^{dd} \end{cases}$$

$$\varphi = 3 \div 12^\circ; \alpha_s = 75^\circ; \quad = 30 \div 50 \text{ meters}$$

Fig. 1. The structure of grapho-analytical model for high bench working by a combined method.

The face side of the model includes the structure of rock formation processing. The dump side of the model includes three schemes of dumping: a single-tier dump, a two-tier dump and a three-tier dump.

The following legend was adopted in the model:

H ó the height of rock formation, m;

H^t , H^{dd} ó respectively, the height of the transport and direct dumping benches, m;

H_{max} , H^t_{max} , H^{dd}_{max} and H_{min} , H^t_{min} , H^{dd}_{min} ó respectively, maximum and minimum heights of rock formation, transport and direct dumping benches, m;

A ó the width of the stope, m;

t ó coal seam thickness, m;

α ó dip angle of the coal seam, degree;

β ó the angle of rock slope, degree

K_d ó coefficient of rock disintegration in a shotpile and in a dump;

E_0 ó the capacity of an internal dump (per meter of the working front), m.

The development of transport sub bench is carried out according to the classical technological scheme characterised by rock excavation and loading by shovel into a dump truck with rock transportation to external or internal dump.

For this model, the schemes of piling the dumps differing in the preparation of additional capacity for any tier have less capacity than the schemes without capacity preparation. Also the width of drilling-and-blasting stopes, the minimum value of which is determined by the condition of the turn of the coal-carrying trucks in the mining faces (35-40 m), does not allow to fully use the discharge radius of the draglines currently used in piling the dump layers.

The use of this model in the design of direct dumping using high benches on the face side of quarry includes the formation of an excavation scheme ó a graphic description of the overburden excavation and its transfer to the internal dump. Excavation schemes (in different or in the same geological conditions) when changing the dragline locations in a profile of a stope differ in their structure, that is, in the number of stages of development and displacement of the rock, as well as in the technological interconnectivity between them. If the number of stages and the technological interconnectivity between them are the same, but the geometric shape of the stages and their sizes can differ, then such excavation schemes can be defined as one-type. According to the proposed structure of the model, each element of the face side (the initial stage of the excavation scheme) can be docked with any element of the dump side (the final stage of the excavation scheme). In addition, by changing the position of the middle seam on the geological structure of the face side, it is possible to reveal the interrelation between the conditions of seams bedding in the formation and the method of its development by high benches, taking into account any of the dump piling schemes.

Results and Discussion

The idealisation of the model for direct dumping bench working is the following. The full use of dragline parameters for piling the dumping layers is accepted. In the proposed model, the direct dumping bench on the face side (the initial stage of the excavation scheme) can be joined to any element of the dump side (the final stage of excavation scheme). Thus, the model allows assigning any number of variants of excavation schemes. An example of a typical scheme with the dumping of a two-tier dump is shown in Fig. 2.

The procedure for calculating the parameters and indicators for high bench processing for transport and direct dumping technologies consist of the following.

First, the parameters and indices of the transportless technological scheme must be determined because the development of direct dumping bench causes the preparation of the seam for excavation and determines the speed of working front movement (Tyulenev et al., 2017).

Then the indicators of intensification of transport sub bench working should ensure non-stop operation of the direct dumping sub bench, i.e. to avoid dragline downtime. Consequently, the condition $V_f = V^{dd}_f$ (where V_f and V^{dd}_f ó the speed of moving the work front on transport and direct dumping technology, respectively) must be observed.

Calculation of the parameters and indices of each stage of high bench working can be done in seven steps. Of them, five steps relate to the calculation of parameters and indicators of direct dumping technology and two ó to the transport one.

Considering these steps in details could help to find the following:

1. For a dragline, considered in a specific variant, the maximum capacity of internal dump (E_0) (one-tier, two-tier and three-tier) is calculated. The maximum equivalent height of strata H^{dd}_{max} (accordingly dump's capacity) is determined by the height of overburden layer, which must be located in the dump with the dump's width equal to A . This task is called *ódirectö* and consists in determining the maximum capacity of the internal dump.

The second stage of calculations is related to the order of assignment variants of direct dumping bench height H_{dd} .

First (the first option), minimum height of the direct dumping bench H_{min}^{dd} is assumed, based on the condition of its scooping by dragline.

Each next variant is characterised by an increase in the height of direct dumping bench by H^{dd} , which can take values of 1, 2, 3 or more meters depending on the required accuracy of calculations.

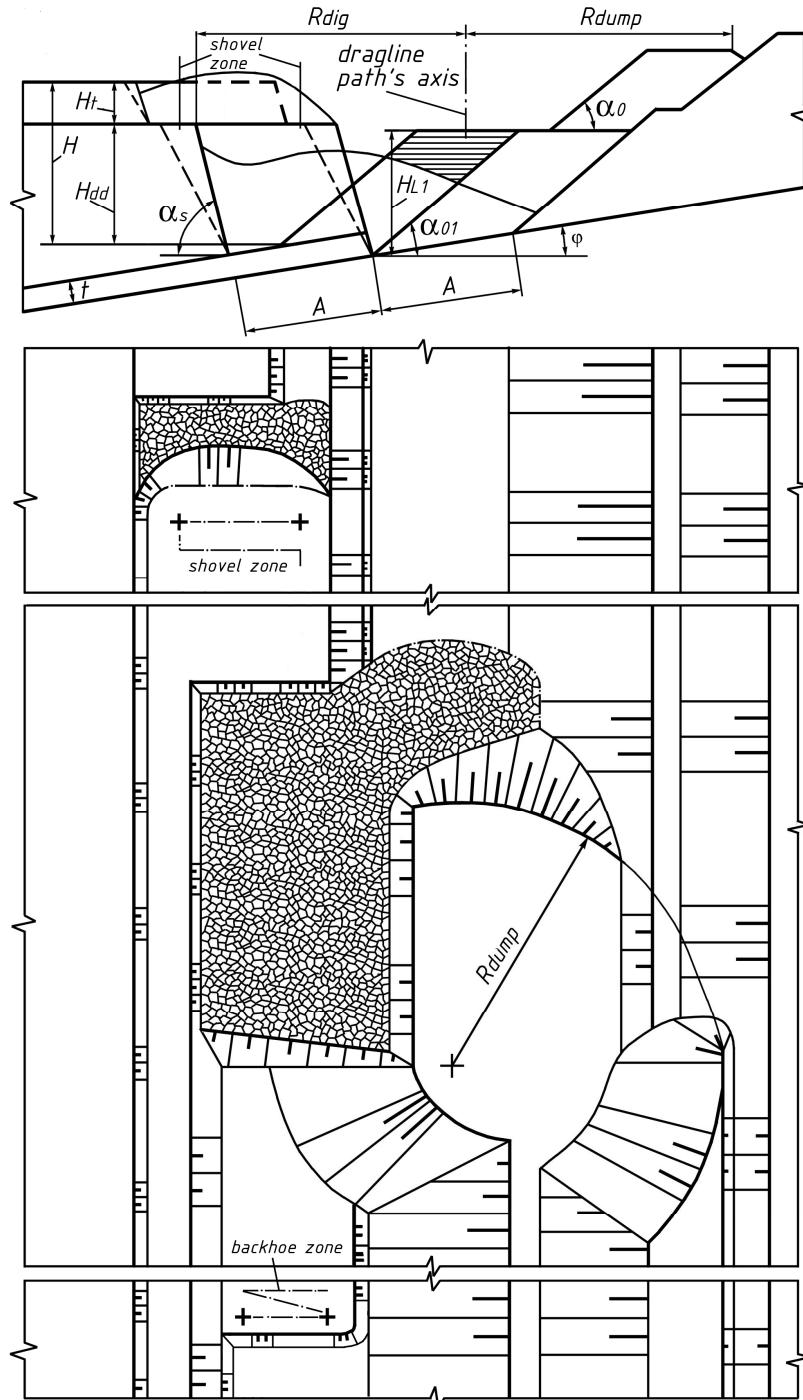

Fig. 2. The typical scheme of excavation with backfilling of a two-tier dump.

2. For each variant under consideration, the rock volume on the face side in the disintegrated state is determined.

Further, by comparing the maximum capacity of the dump and the actual rock volume of the face side, the number of dump tiers and the actual height of one-tier dump, the second tier of the two-tier dump and the third tier of the three-tier dump are determined.

Thus, at the second stage, the *öreverseö* task is fulfilled: according to known rock volume on the face side, the number of dumpø tier and its parameters in the final (static) position are determined.

3. The parameters of drilling and blasting operations, the parameters of the collapse are calculated, and the coefficient of explosive rock discharge is determined.
4. The dynamics of rock movement from the face side to the dump is projected, for which the structure of the excavation scheme and its parameters are determined by the grapho-analytical method. The schemeø re-excavation rate in mining profile and annual effective dragline productivity are determined.
5. The main technical and economic indicators (volumes of mined coal, stripping ratio, the productivity of draglines, direct costs of stripping and coal mining, etc.) of direct dumping technology are determined.
6. For already established annual speed of mining front moving for direct dumping technology (V^{dd}), the transport technology indicators are calculated for a predetermined overburden excavator. The annual economic indicators and the necessary number of excavators are calculated or adopted according to the practice data.
7. The technical and economic indicators of the combined high bench working and the magnitude of the evaluation criterion are calculated. Further, these steps of calculations are repeated for each variant, which parameters are chosen in advance.

As it was mentioned above, the solution of the ödirectö task involves determining the maximum capacity of the internal dump. For given dragline, first, the maximum capacity of the internal dump (of one-, two- and three-tier), as well as the maximum equivalent height of the strata H^{dd}_{max} , is calculated. One of the most important indicators for this is the **general angle of the internal dumpø slope**. Fig. 3 (a, b, c) shows the scheme for calculating parameters and maximum capacity of internal dumps.

The following legend is used on the schemes in Fig. 3:

1. Working parameters of the dragline, piling dumping layers, and the parameters of its safe installation:
 - R_{dig} , R_{dump} , H_{dump} , H_{dumpr} , R_r , W_{pass} ö respectively: digging radius, dumping radius, dumping height, digging depth, the radius of rotation and width of excavatorø path (for dragline engaged in the formation of the first and second tiers), m;
 - B ö minimum distance from the axis of draglineø path to the upper edge of the underlying tier, m;
 - b_n ö minimum distance between the draglineø shoe when working and walking and the upper edge of the underlying tier, m (3-4 m).
2. General parameters of all dumping schemes:
 - α_0 ö the natural angle of slope for rock in the dump, degrees (37°);
 - γ_g ö the general angle of internal dumpø slope, degrees;
 - B_{berm} ö the estimated width of the berm between the upper edge of the first tier and the lower edge of the second tier, m;
 - h ö the value of lowering of the dump layer between two adjacent stopes, m;
 - A_g ö horizontal width of dumpø tires, m;
 - S_{pr} ö the volume of rock in the second (third) tier, placed there during piling of the first (second) tier of the previous dump, m^3 ;
 - $L1^{max}$, $L2^{max}$, $L3$ ö respectively: the capacity of the first, second and third tier per one meter of working front (specific capacity), m^3 ;
 - H_{SL1} , H_{SL2} ö the height of tiersø first and second slopes, m;
 - H_{t1} , H_{t2} , H_{t3} ö respectively: heights of 1st, 2nd and 3rd dump tiers;
 - H_D ö height of whole internal dump (H_{D1} , H_{D2} , H_{D3} ö heights of single-tier, two-tier and three-tier internal dump);
 - ö empty capacity in the dump tier due to the insufficient value of draglineø dumping radius (Fig. 3- b, c);
 - ö the width of empty capacity in the upper part of dump tier (Fig.3-b, c), left unoccupied during its piling due to the discrepancy of draglineø dumping radius R_{dig} and the horizontal width of the dumping tier A_g , m.

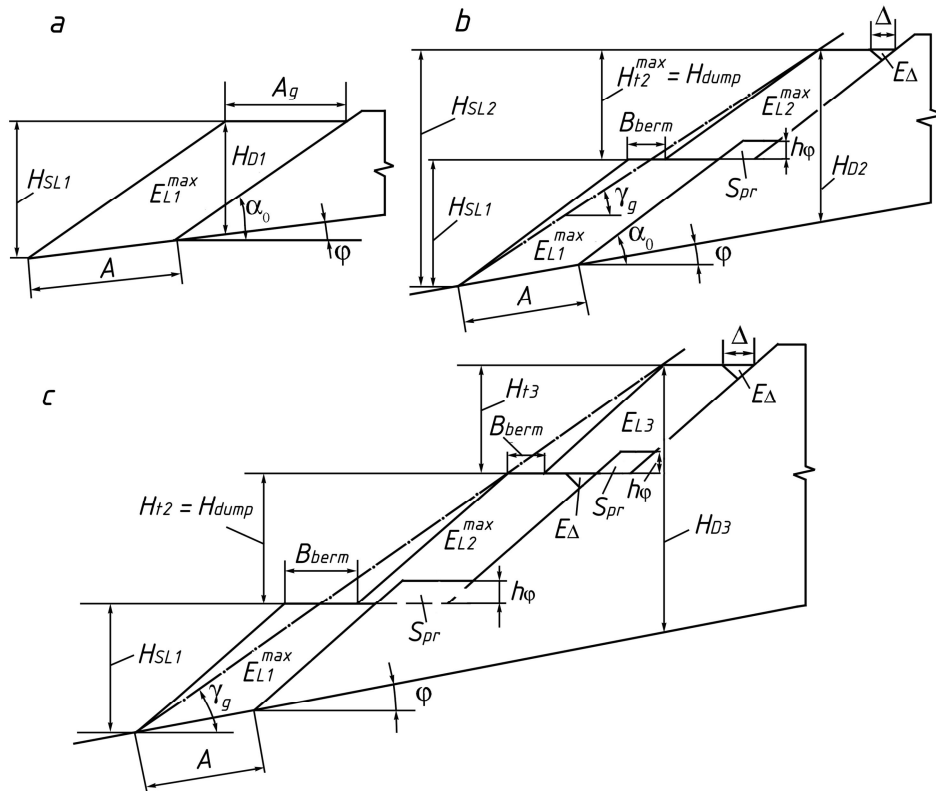

Fig. 3. The schemes for calculating parameters and maximum capacity of the dumps: a - single-tier, b - two-tier, c - three-tier (the solution of direct task).

The value of parameter E is determined on the analysis of the plot of empty capacity ($E = 0.25 \cdot A_g^2 \cdot \tan^2 \alpha_0$) on the ratio $K = \Delta / A_g$ (Fig. 4).

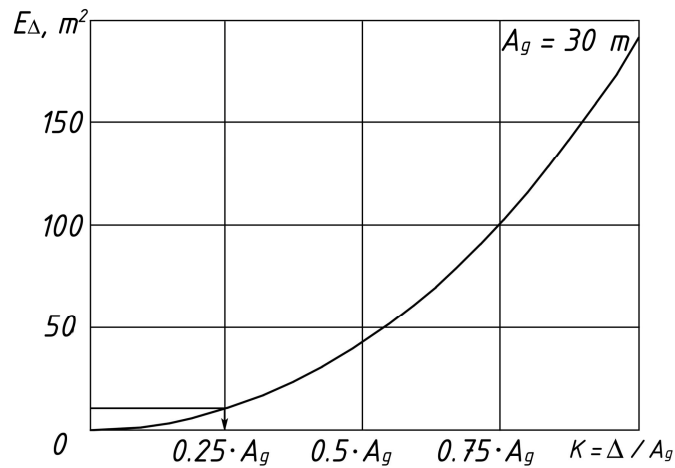

Fig. 4. The dependence of empty capacity E_{Δ} on the ratio $K = \Delta / A_g$.

As can be seen from the plot in Fig. 4, the empty capacity E increases in quadratic dependence on the width of the cut-off layer A_g . From the point of view of minimising empty capacity E , the value of K parameter can be taken to be equal to the fourth part of A_g ($K = 0.25 \cdot A_g$). In this case, the smallest capacitance value E takes place with sufficient use of the dumping radius of the dragline.

The definition of the general angle of dump's slope is made in the following order:

1. When dumping a single-tier dump (for variants of excavation schemes with a small height of direct dumping bench of 10-15 m), the general angle of dump's slope α_g is equal to the natural angle of slope $\alpha_0 = 37^\circ$. The height of the slope of the first tier is assumed to be equal to 25 m ($H_{SL1} = 25$ m), according to the recommendations of Kuzbass State Technical University (Kemerovo, Western Siberia, Russian Federation).
2. When dumping two- and three-tier dumps, the angle α_g is determined using the dependences $\alpha_g = f(H_D; \dots)$.

$$V_{int}^{dump} = H_{dd} \cdot A \cdot \left(\frac{\sin \varphi}{\tan \alpha_0} + \cos \varphi \right) \cdot K_d, \tag{1}$$

then:

$$H_D = \frac{V_{int}^{dump} + 0.5 \cdot A \cdot A_g \cdot \sin \varphi}{A_g \cdot \left(1 + \frac{\cot \alpha_0}{\cot \varphi - \cot \alpha_0} \right)}, \tag{2}$$

where:

$$A_g = \frac{A \cdot \sin(\alpha_0 - \varphi)}{\sin \alpha_0}. \tag{3}$$

Further, according to the dependence $\gamma_g = f(H_D; \varphi)$ (Fig. 5), for known φ we find γ_g and the result of the calculation is expressed in round numbers.

Table 1 gives the recommendations for defining the general slope angle of internal multi-tier dumps depending on the total height of the dump and the angle of inclination of its base.

Tab. 1. The general slope angle of internal multi-tier dump.

Soft ground (coal clay, carbon-bearing mudstone, soft mudstone and siltstone)	The angle of inclination of dumps base , degrees	The general slope angle of internal multi-tier dump γ_g , degrees, for its total height H_D , m x 6 maximum values of slop angle					
		20	30	40	60	80	100
	3	32-37	26-37	22-34	20-31	29 ^s	6
	6	28-37	21-37	32 ^s	29 ^s	27 ^s	6
	9	23-35	31 ^s	28 ^s	25 ^s	22 ^s	6
	12	32 ^s	27 ^s	24 ^s	6	6	6

According to Tab. 1, a family of dependences $\gamma_g = f(H_D; \varphi)$ was obtained (Fig. 5). These dependencies are used in calculating the parameters of excavation schemes with different heights of direct dumping sub bench and, consequently, with the piling of internal heaps of a different number of tiers. The results allow keeping further calculations to determine the capacity of single- and multi-tier dumps.

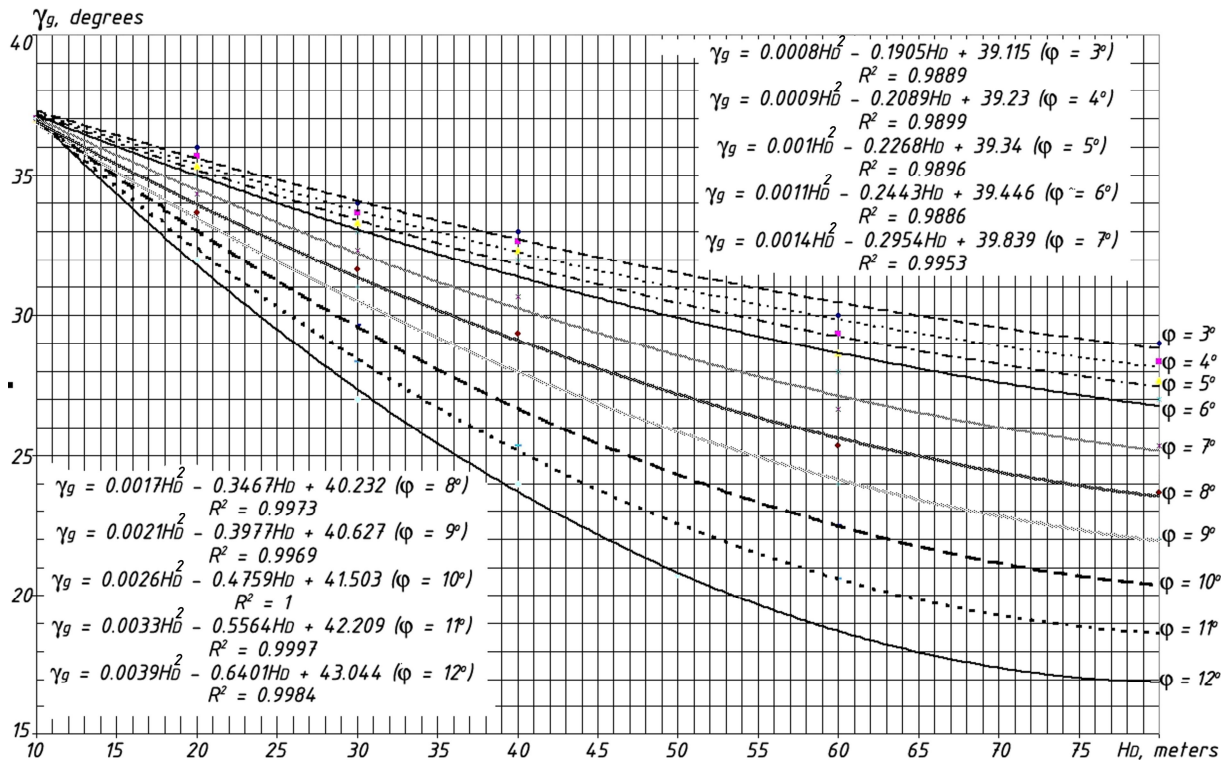

Fig. 5. The dependences of general slope angle of internal multi-tier dump (γ_g) on its height (H_D) and angle of inclination of its base (φ).

Conclusions

1. The architecture of face and dump sides of open coal pit implies modelling of the key parameters of direct dumping technology and defining general angles of internal multi-tier dumps for landslides avoiding and safety providing. Therefore, we recommend determining the minimum height of the direct dumping bench based on the comparison of dump's maximum capacity and the actual volume of the face side, taking into account the number of dump tiers and their actual height. Such a calculation must be iterated for a single-tier dump, the second tier of a two-tier dump and the third tier of a three-tier dump. Based on the analysis of the results obtained, the optimal version of the high bench development technology that meets the stated requirements or has the best technical and economic indices can be selected.
2. Based on the studies and calculations carried out, we concluded the following: the general slope angles of multi-tiered internal dumps, which base is composed of soft rocks, should not exceed 24-29° at the height of 40-60 m, and the height of the slope of the first tier (the natural slope angle is 37°) should not be more than 20-25 m.
3. Using the method of direct dumping technology parameterisation at open coal pits developed by high benches allows optimising draglines work and avoiding rock slide on the dumping side of the pit.

Acknowledgements: The research is carried out at Tomsk Polytechnic University within the framework of Tomsk Polytechnic University Competitiveness Enhancement Program grant.

References

- Agafonov, F., Genin, A., Kalinina, O., Brel, O. and Zhironkina O. (2017). Technological convergence and innovative development of natural resource economy. *E3S Web Conferences*, 15, pp. 04011.
- Alarie, S. and Gamache, M. (2002). Overview of solution strategies used in truck dispatching systems for open pit mines. *International Journal of Surface Mining, Reclamation and Environment*, 16(1), pp. 59-76.
- Baafi, E.Y. Mirabediny, H. and Whitchurch, K. (1997). Computer simulation of complex dragline operations. *International Journal of Surface Mining, Reclamation and Environment*, 11, pp. 7-13.
- Cehlár, M. and Cehlárová, I. (2007). Cut winnings methods of an open-pit mine development. *Acta Montanistica Slovaca*, 12(3), pp. 174-181.
- Cehlár, M., Jano ko, J., Týnková, Z. and Pavlik, T. (2017). Assessment process of concept for mining and its impact on the region. *E3S Web of Conferences*, 15, pp. 01019.
- Demirel, N. and Duzgun, H.S. (2011). Risk assessment for dragline productivity: A case study of GLI's draglines in Turkey. *SME An. Meet. Ex. 113th Nat. West. Min. Conf.*, pp. 630-635.
- Erdem, B. and Çelebi, N. (1998). An approach to design a dragline pit in pullback stripping method. *International Journal of Surface Mining, Reclamation and Environment*, 12, pp. 189-195.
- Gvozdkova, T., Kuznetsov, E.; Rudakova, A. and Markov S. (2017). The features of three- and four-tier internal dumps capacity calculation with the additional capacity preparation in the dump tiers. *E3S Web of Conferences*, 15, pp. 01008.
- Hrehová, D., Cehlár, M., Rybár, R. and Mitterpachová N. (2012). Mining technology with drilling-blasting operations. *Proceed. 12th Int. Multidis. Sci. GeoConf. SGEM2012*, pp. 675-682.
- Karpuz, C. (1990). A classification system for excavation of surface coal measures. *Mineral Science and Technology*, 11(2), pp. 157-163.
- Katsubin, A.V. and Makridin, E.V. (2018). Systematization of the technological schemes of excavator faces at the central Kuzbass open pit mines. *Journal of mining and geotechnical engineering*, 1(1), pp. 81. DOI: 10.26730/2618-7434-2018-1-81-88
- Malli, T., Pamukcu, C. and Kose, H. (2015). Determination of Optimum Production Capacity and Mine Life Considering Net Present Value in Open Pit Mining at Different Overall Slope Angles. *Acta Montanistica Slovaca*, 20(1), pp. 61-70.
- Markov, S., Tyulenev, M., Litvin, O. and Tyuleneva, E. (2017). Innovative numerical modelling of technogenic rock arrays structure. *E3S Web of Conferences*, 15, 01011.
- Martyanov, V.L. (2018). Evaluation of the working out difficulty of quarry fields on Kuzbass coal deposits. *Journal of mining and geotechnical engineering*, 1(11), pp.35. DOI: 10.26730/2618-7434-2018-1-35-41
- Mirabediny, H. (1998). A dragline simulation model for strip mine design and development. PhD Dissertation, University of Wollongong.

- Prakash, A.; Mallika, V. Murthy, S.R. and Singh, K.B. (2013). Rock excavation using surface miners: an overview of some design and operational aspects. *International Journal of Mining Science and Technology*, 23, pp.33-40.
- Trnková, Z., Cehlár, M. and Pavolová, H. (2016). Strategy of point out relevance of responsible exploitation of mineral resources. *Acta Montanistica Slovaca*, 21(3), pp.208-216.
- Tyurin, A.Yu. (2017). Planning of transport and logistics operations at the strategic and tactical levels of decision-making. *Economics and Innovation Management*, 2, pp. 97-110. DOI:10.26730/2587-5574-2017-2-97-110
- Tyulenev, M.A., Gvozdikova, T.N., Zhironkin, S.A. and Garina, E.A. (2017). Justification of Open Pit Mining Technology for Flat Coal Strata Processing in Relation to the Stratigraphic Positioning Rate. *Geotechnical and Geological Engineering*, 35, pp.203-212.
- Tyulenev, M.A., Markov, S.O., Gasanov, M.A. and Zhironkin, S.A (2018). Numerical Modeling in the Structural Study of Technogenic Rock Array. *Geotechnical and Geological Engineering Volume*, 36(5), pp. 2789-2797.
- Vukotic I, Kecojevic V., Zhang W., Cai Q. and Chen S. (2013). Optimization of transport passage with dragline system in thick overburden open pit mine. *International Journal of Mining Science and Technology*, 23(6), pp.901-906.