

Shield Support Monitoring System – operation during the support setting

*Dariusz Jasiulek¹, Sławomir Bartoszek¹, Karel Perůtka², Aleksandr Korshunov³,
Jerzy Jagoda¹ and Marek Płonka⁴*

The paper presents the results of testing the geometry measurement system of powered roof support using inclinometers that meet the requirements of the ATEX directive. Mechanized longwall system is most often used for coal mining. The longwall system includes basic machines, such as a longwall shearer, AFC and powered roof support that protects the roof. The powered roof support consists of the units that are hydraulically or electro-hydraulically controlled and are equipped with pressure sensors in the selected places of the hydraulic system and displacement sensors for selected actuators. One of the challenges associated with controlling and monitoring the parameters of the powered roof support is the mapping of its geometry and arrangement of individual components. KOMAG Institute of Mining Technology designed and manufactured the geometry monitoring system based on inclinometers that meet the requirements of the ATEX Directive. The system was tested on a real object in the laboratory. Impact of the structure of the powered roof support on the accuracy of geometry measurement and mapping was determined based on the test results. The results of the tests will be used during the implementation of the system in real conditions.

Keywords: powered roof support geometry; ATEX directive; inclinometer; battery.

Introduction

In 2017 KOMAG Institute of Mining Technology started realization of PRASS III (Productivity and safety of shield support) project (PRASS III project website). The project is co-financed from the Research Fund for Coal and Steel (RFCS) as well as from the Ministry of Science and Higher Education. The project is realized by the international consortium consisting of the companies from Poland (GIG Central Mining Institute, KOMAG Institute of Mining Technology, Jastrzębska Coal Company S.A., Becker Warkop Sp. z o.o.), from Germany (DMT GmbH & Co. KG), Great Britain (University of Exeter) and Spain (Geocontrol S.A.). Development of the measuring system dedicated to powered roof supports as well as the system for rockfall prediction is the main project objective.

The work carried out within the PRASS III project is aimed at developing the monitoring system allowing for visualization and assessment of operational parameters of powered roof supports. The most innovative functions of the Shield Support Monitoring System (SSMS) include measuring the width of the tip-to-face path and monitoring the geometry of the powered roof supports. These parameters are important for the stability of the longwall and correct interaction between the roof support and the rock mass, and in certain conditions, they may affect the possibility of damage to the roof support components.

In the Polish mining industry, mechanised shield support is rarely monitored, unlike other machines in the longwall complex. The effectiveness and safety of mining operations depend on shield support. Aspects related to the cooperation between mechanised shield support and rock mass, which affect the proper maintenance of the roof, have a significant impact on the effectiveness and safety of hard coal mining. The stability of the roof is affected, among others, by the tip to face distance, the support parameters of the shield support (initial and working support), the control system and the height of longwall (Bronya, Wiklund et al., 2011).

A lot of research work is carried out in the world, related to modelling the behaviour of a mechanized shield supports and the roof. This modelling is carried out on the basis of actual data recorded during mining or on the basis of theoretical assumptions (Bronya Wiklund et al., 2011, Langosch et al., 2003). The results of the model work unequivocally indicate that the proper operation of the powered roof support is necessary from the point of view of the effectiveness and safety of coal production. Supporting the operator and preventing potential mistakes made by the operator is possible only in the case of monitoring the basic parameters of the shield support operation and analysing their changes and trends in real-time.

Work is underway to develop algorithms for prediction of roof behaviour in a mechanized longwall complex. The paper (Herezy et al., 2018) presents an algorithm for prediction of the behaviour of shield support based on

¹ Dariusz Jasiulek, Sławomir Bartoszek, Jerzy Jagoda, KOMAG Institute of Mining Technology, ul. Pszczyńska 37, 44-101 Gliwice, Poland, djasiulek@komag.eu, sbartoszek@komag.eu, jjagoda@komag.eu

² Karel Perůtka, Tomas Bata University in Zlín, Faculty of Applied Informatics, T.G.Masaryka 5555, Zlín, Czech Republic, KPerutka@utb.cz

³ Aleksandr Korshunov, Federal State Budgetary Institution of Science «Udmurt Federal Research Center of the Ural Branch of the Russian Academy of Sciences» Institute of Mechanics, T. Baramzinov str., 34, Izhevsk, Udmurt Republic, Russia, maguser_kai@mail.ru

⁴ Marek Płonka, GIG Central Mining Institute, Plac Gwarków 1, 40-166 Katowice, Poland, mplonka.@gig.eu

pressure in hydraulic cylinders and the position of a mining machine in a longwall. The prediction of the roof behaviour is most often performed on the basis of changes in the pressure in hydraulic cylinders caused by the character of the powered roof support operation and the influence of the rock mass. The results of works related to the analysis of pressure changes are presented in the paper (Wang et al., 2018) in relation to coal seams in the Shendong coalfield, located in the northwest of China. In work (Jingyi Cheng et al., 2018) present software package SSRI, to analyze monitoring data from leg pressure. The paper (Verma et al., 2016) presents the use of artificial neural networks to determine the working pressure of hydraulic cylinders in the shield support. Work in the field of co-operation between the shield support and the rock mass is the subject of many analyses (Jing Xuan Yang et al., 2017). The results of this work are used at the stage of designing shield support for specific mining and geological conditions but are not taken into account in the process of control.

The geometry measurement can also be used to obtain information about the load of the shield support. It will be an indirect measurement, but direct measurement of the load is technically difficult in real conditions, as indicated by the results of work (Witek and Prusek, 2016, Kalentev et al., 2017). The authors presented the results of the GEOSOFT project, in which complex tests of the shield support unit in various support conditions were performed.

The inclinometers should be installed primarily in newly designed support units. In the design process (Yang et al., 2018, Swedish et al., 2016, Siegfried, 2013) it is possible to introduce full geometry information and to install inclinometers to ensure their safe use.

Justification for monitoring the geometry of shield support

Operation of the roof support with the correct geometry, understood as the parallelism of the canopy and the base, is important for the interaction of the roof support with the rock mass. This fact is particularly important in the case of weak rocks in the roof or in the case of mining the longwall under the rockfall zone. In such conditions it is important to operate the powered roof supports properly, so as not to create a linear contact between the canopy and the roof, which may cause damage to the structure of roof rocks. Roof fall risk in longwall coal faces is presented in work (Prusek et al., 2016).

Operation of the roof support with incorrect geometry also affects the distribution of base pressure on the floor. This problem was illustrated by the method used in the Department of Extraction Technologies and Mining Support at GIG and with software for the analysis of geometry and distribution of forces in roof support nodes (Płonka, 2009). For example, lifting the canopy of powered roof support results in changing the distribution of pressures on the floor (Płonka and Rajwa, 2018). In the case of raising the canopy, the highest pressure on the floor occurs closer to the coal face, which may lead to the roof support tendency of sinking into the floor and in extreme cases leading to loss of stability.

The analysis of the forces at the powered roof support structure nodes should be taken into account when considering the impact of the roof support design on its failure (Fig. 1). This problem is described in the publication (Płonka and Rajwa, 2018) where, based on the case study, it is described how the lifting of the canopy end affected the increase in strength at the point of connection between the canopy and the caving shield. It was determined that the forces in the roof support construction nodes might differ significantly from the model usually used in the Operational Manual for the horizontal position of the canopy and base. It was found that the changes in forces in the joint node of the canopy with the caving shield depend mainly on the specific form of kinematics and then on the inclination between the canopy and base and on the load to the caving shield of the roof support.

In the mathematical models, it was confirmed that for the specified lifting angles of the canopy by 8° and 12° (inclinations found in a particular longwall), the forces at the connection between the canopy and the caving shield are significantly higher than the forces calculated in the case of operation with the horizontal canopy (Płonka and Rajwa, 2018, Rajwa et al., 2017).

Work on inclinometers is carried out by DOH Centrum Hydrauliki company, among others. The inclinometers have their own battery power supply and are adapted to work on the shield support (Szurgacz and Brodny, 2019). The paper (Prusek et al., 2016) presents measurements of shield support geometry; however, they were performed in laboratory conditions.

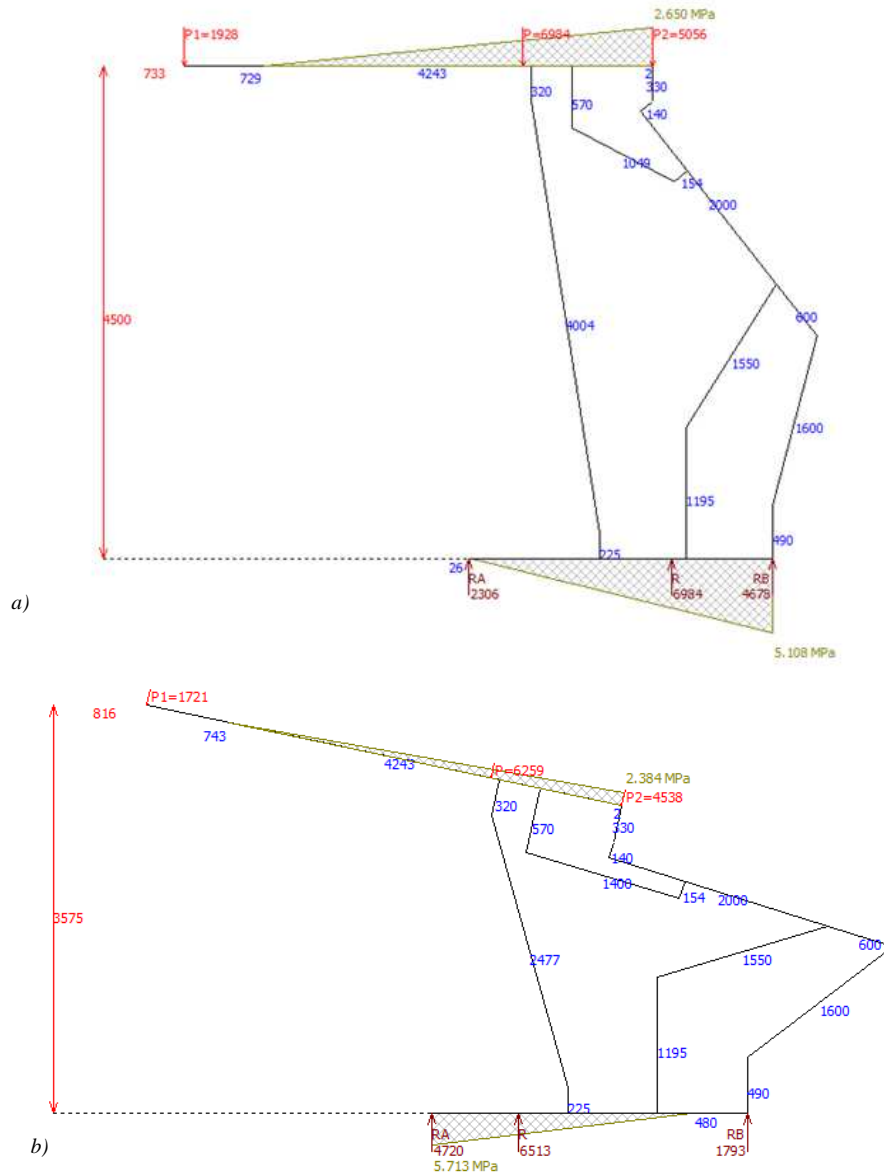

Fig. 1. Distribution of pressure on the roof and floor depending on the shield support geometry: a) canopy parallel to the floor; b) canopy raised at an angle of 12°. (Płonka and Rajwa, 2018)

System design

The models and prototypes of system components were developed within the PRASS III project, and then they were certified in accordance with the ATEX Directive and tested in real conditions. The shield support monitoring system consists of the following three modules (Fig. 1):

- SSMS-C - central unit for communication with individual modules, power supply, archiving and data transmission.
- SSMS-I - two-axis inclinometer.
- SSMS-S - "tip to face" sensor, a module that detects the distance between the mechanized housing section and the longwall face.

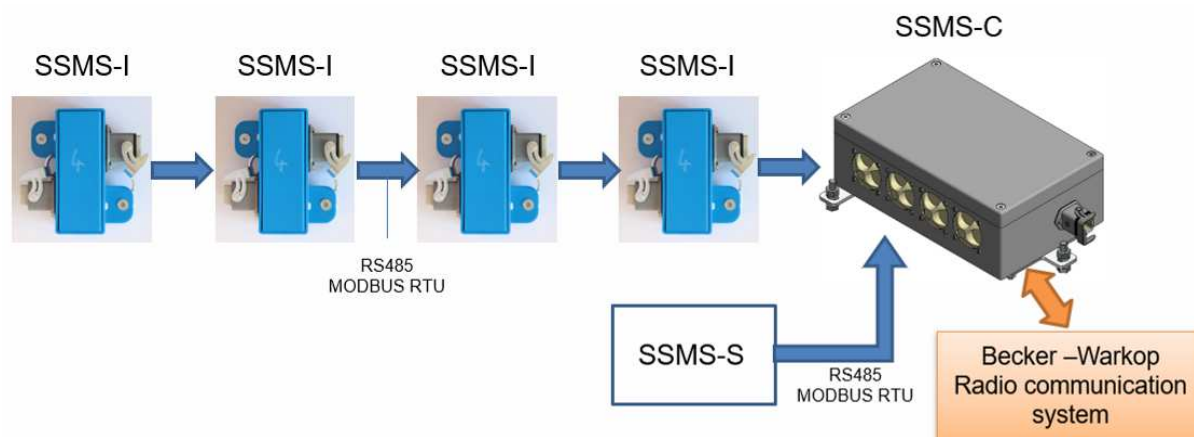

Fig. 2. SSMS system design.

Each module of the SSMS is placed on the powered roof support components (Fig. 3). In order to be able to place each SSMS-I inclinometer module in appropriate places in the powered roof support (to ensure correct reading of measurement data), the dimensions of the device enclosure were minimized. In order to reduce the size of the SSMS-I module, each inclinometer system did not have its own power source; it was power supplied from the SSMS-C central unit (which was located on the canopy of roof support, this place allows to install this device).

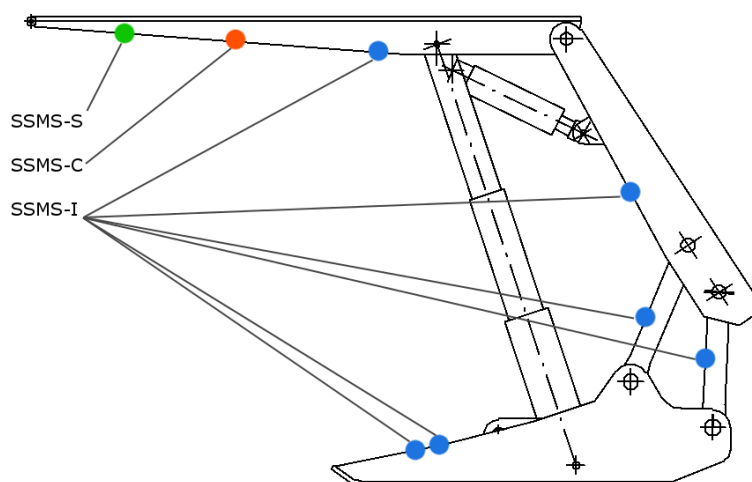

Fig. 3. Arrangement of SSMS components on the powered roof support

To simplify the communication system and ensure adequate radio visibility, the module responsible for communication of all system components for single powered roof support was placed in the SSMS-C central unit. On the slope, there is also an SSMS-S track measurement module, which has an independent battery circuit and data from the module are sent by cable to the SSMS-C central unit. Communication between SSMS-C units will be based on distributed algorithms (Stankiewicz, 2018; Baranov et al., 2017).

SSMS-C module

The SSMS-C central unit module (Fig. 4) is used for power supply, communication, archiving and data transmission. It is equipped with 4 primary cells of a capacity 70mAh enabling the system to operate for at least one year. The unit is adapted to be mounted on powered roof support and connected with SSMS-I inclinometer modules and SSMS-S path sensor. Data are transmitted using the MODBUS-RTU protocol. Data collected from each module are initially processed, archived in non-volatile memory and sent by radio to the superior unit.



Fig. 4. SSMS-C central unit module.

During the designing process of the unit, it was necessary to provide IP65 protection level of the unit enclosure against dust and water ingress. The device is designed to operate on the powered roof support of a longwall system in conditions of an underground hard coal mine. Working conditions in longwall faces are characterized by a high level of airborne dust. To reduce dust concentration, water spraying systems are used, which means that the equipment working in this place should have a high level of protection against water penetration.

In order to ensure IP protection level of 65, the ROSE company selected an enclosure with the manufacturer's declaration of IP65 protection level. Selected battery compartments also had the IP 67 protection level provided by the manufacturer. Selected Harting connector for data transmission and power supply of individual modules of the system had IP 67 protection level. All screwed fittings were equipped with the appropriate seal to ensure the required protection level (Qazizada and Pivarčiová, 2018).

The requirements of the working environment in which the device will operate also require that the device operates in the temperature range from $-20\text{ }^{\circ}\text{C}$ to $+50\text{ }^{\circ}\text{C}$. This requirement is met by selecting the enclosure components that meet these criteria. Also, all electronic components were selected to ensure safe working temperature (in accordance with the ATEX Directive), taking into account the operating temperature of the device.

Due to the requirements of the ATEX Directive, the short-circuit current from the cells had to be limited. It was also important to connect the batteries to ensure a sufficiently high voltage supplied to the device. The batteries were therefore connected in series-parallel. The connection of two cells in series ensures that the power supply voltage is increased by doubling the voltage coming from a single cell and affects the reduction of short circuit current (in its calculation we take into account the double value of the cell internal resistance).

SSMS-C is characterized by the following operational parameters:

- ATEX parameters: I M1 Ex ia I Ma
- Ambient temperature: $T_a = -20\text{ }^{\circ}\text{C}$, $+50\text{ }^{\circ}\text{C}$
- Protection class: IP65
- Power of the transmitter: 17 dBm (50 mW)
- Capacity: 4 x 3.6 V 17Ah.

SSMS-I module

Two-axis inclinometer SSMS-I (Fig. 5) is designed to be mounted on the components of powered roof support. The inclinometers are battery-powered (from the SSMS-C central unit, which is placed on each roof support), so there is no need to run power cables between the roof supports. Up to 6 inclinometers can be installed on one roof support.

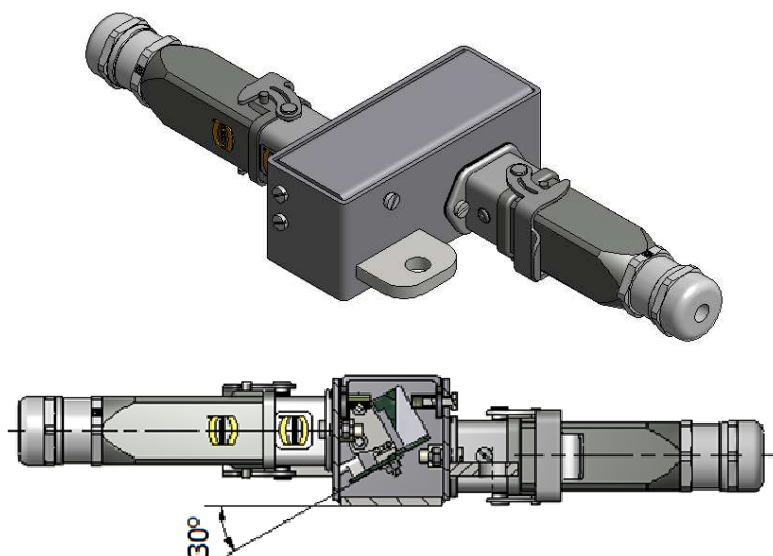

Fig. 5. SSMS-I inclinometer module

As in the case of the SSMS-C central unit, it was necessary to provide IP65 protection of the inclinometer enclosure against dust and water ingress, as it is designed to operate in underground mine conditions.

In order to increase the mechanical resistance, the inclinometer enclosure is made of steel. In order to ensure that the enclosure is waterproof and dust-proof, the SSMS-I enclosure was additionally sealed. The filler also acts as a heat dissipator for individual electronic components. The applied electronic components have been selected so as to meet the requirements of the ATEX Directive for equipment applied in the operating temperature range from $-20\text{ }^{\circ}\text{C}$ to $+50\text{ }^{\circ}\text{C}$.

The use of a two-axis inclinometer allows determining the position of the enclosure assembly in two axes. One of them is the side tilting of the enclosure (the enclosure of the longwall complex is never horizontal). The inclination is an important parameter to determine the supporting capacity, which is determined in a direction parallel to the gravity force.

The analysis of the mechanized enclosure geometry showed that in some designs, during the operation, the bracket angle of inclination exceeded 90 ° . In order to avoid such a situation, the printed circuit board with built-in inclinometers was inclined at the angle of 30 ° (Fig. 6). This also improves the measuring accuracy of the inclinometer. The SSMS-I inclinometer, designed and manufactured in this way, is shown in Figure 6.



Fig. 6. SSMS-I inclinometer module.

SSMS-I is characterized by the following operating parameters:

- ATEX parameters: I M1 Ex ia I Ma;
- Ambient temperature: $T_a = -20\text{ }^{\circ}\text{C}$, $+50\text{ }^{\circ}\text{C}$;
- Protection class: IP65.

Tests

JZR 13/28 POZ shield support was tested (Fig. 7). Inclinometers were installed on the shield support using the magnetic mounting. Four SSMS-I inclinometers were installed – on the base, on the canopy, on the goaf shield and on the lemniscate linkage. Places of the inclinometers installation are presented in Figure 8. Data from the inclinometers were recorded using the computer programme developed especially for the tests. Sampling frequency was 500 ms.



Fig. 7. JZR 13/28 POZ shield support



Fig. 8. Model of SSMS-I inclinometers: a) on the base, b) on the canopy, c) on the goaf shield, d) on the lemniscate linkage



Fig. 9. Test rig

The main purpose of the tests was to verify the correctness of inclinometer measurements in conditions close to real ones. The test rig was used for functional analysis of powered roof supports (Fig. 9). The test rig enables simulations of the roof support operation in inclined seams (up to 40 degrees), and roof support set up keeping the working pressure. The roof of the test rig is set up to the selected height and is locked with bolts, which creates a rigid frame structure in which the roof support is set up. The test's objective was to verify the correctness of readings in the case of roof support being set up against a rigid roof.

This process is associated with the elimination of backlash on powered roof support pins and roof locks (this process is often dynamic).

Figures 9, 10, 11 and 12 show the angles of the individual components of the shield support during the tensile test in the test rig - the nominal pressure in cylinders was assumed to be 24 MPa. The tests were started at the canopy placed in parallel to the rig roof in the distance of 20 cm.

The tests were conducted in five stages:

- Stage 1 - the shield support without any resistance travels through the empty space between the rig roof and the canopy (time period from 110th to 142nd seconds).
- Stage 2 - the time period between the canopy edge contact with the floor (142nd second) and the whole canopy plane contact (145th second).
- Stage 3 - pressing the canopy to the rig roof (145th second).
- Stage 4 – elimination of clearances - rapid adjustment of the shield support components (153rd second)
- Stage 5 - the shield support stabilization (153rd – 170th seconds).

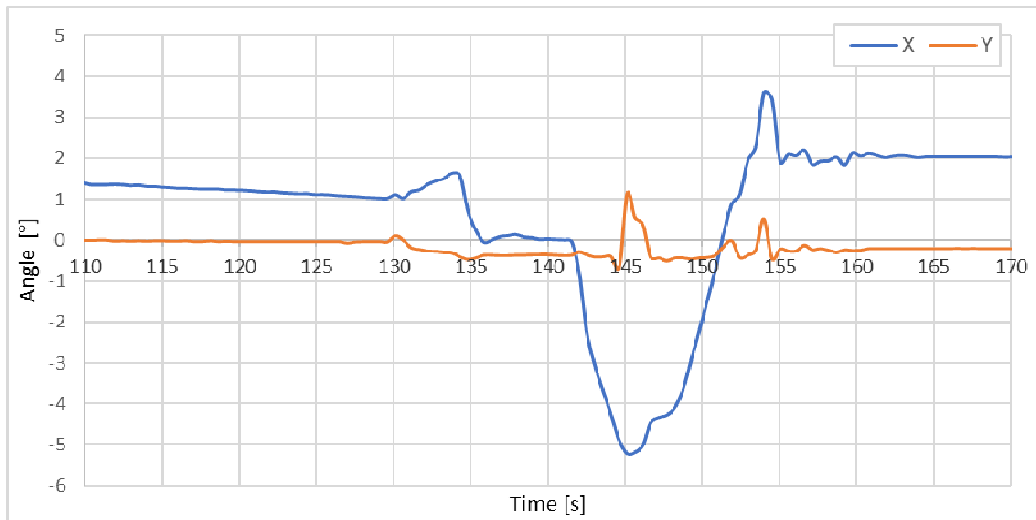

Fig. 9. The angle of the canopy during the tests

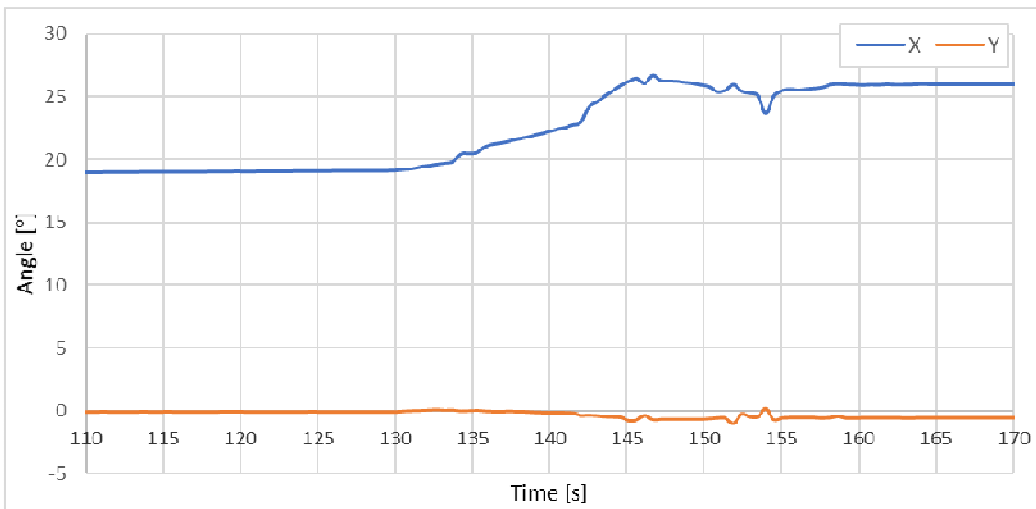

Fig. 10. The angle of the goaf shield during the tests

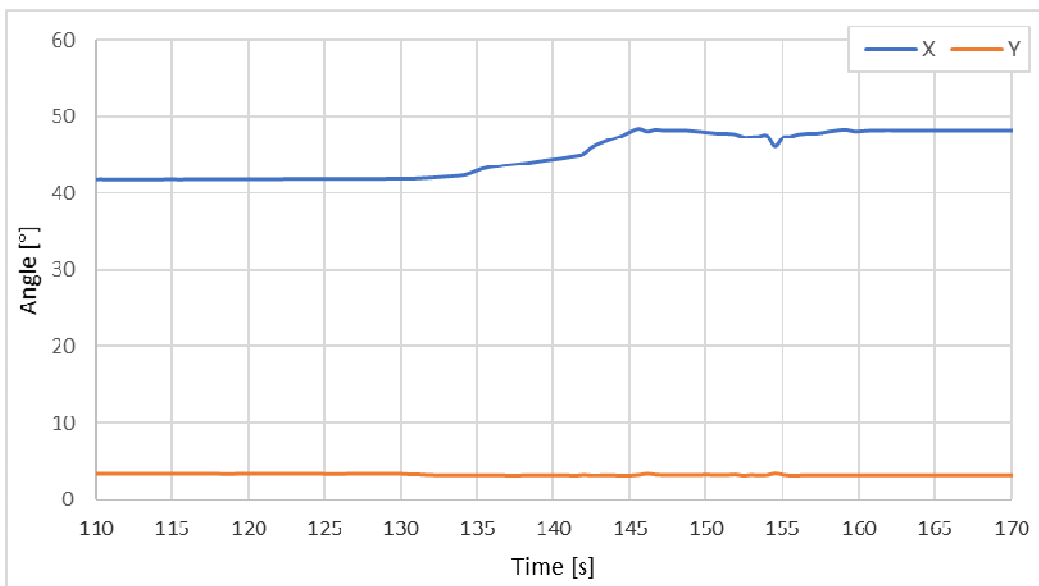

Fig. 11. The angle of the lemniscate linkage during the tests

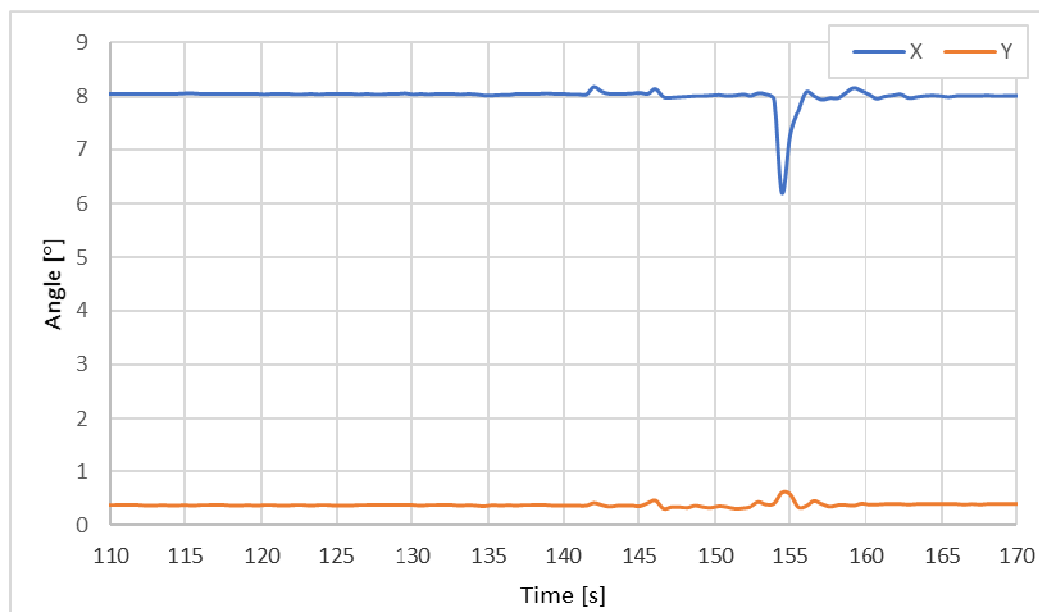

Fig. 12. The angle of the base during the tests

The results of the tests confirmed that the design of inclinometers and the applied algorithms of signal filtering are correct and resistant to dynamic phenomena. The measurement results presented on the chart were averaged through a low pass filter. There are no oscillations after the angle change and no vibrations from the dynamic removal of backlash in the tests of the powered roof supports.

Summary

It was assumed that monitoring and analysis of powered roof support operational parameters in real-time using SSMS enable to predict the hazards associated with the fall of roof rock. The KOMAG Institute of Mining Technology designed and made a geometry monitoring system based on inclinometers that meet the requirements of the ATEX Directive. System tests were carried out on a real object in laboratory conditions. The tests confirmed the correct operation of the SSMS system. The next step will be to make the prototype and install it in real mining conditions. The tests of the impact of clearances in structural nodes on the accuracy of the measurement system will also be carried out.

The aim of the research was to determine whether the applied filtration algorithms will allow monitoring the geometry in shield support in the case of dynamic changes. During the contact between the shield support canopy and the roof of the test rig, changes in the position of shield support components, resulting from an adjustment to the roof, took place and the shield support eliminated clearances on the connecting components (pins). In the case of monitoring the shield support geometry during operation, the support unit advancing process will be omitted - these changes will not affect long-term trends and can be regarded as interference.

Funding: The research work undertaken in PRASS III (Productivity and safety of shield support), grant 752504 (2017) was supported by EU Research Fund for Coal and Steel (RFCS) as well as the Ministry of Science and Higher Education.

References

- ATEX Directive 2014/34/EU
Baranov, M., Bozek, P., Prajova, V., Ivanova, T., Novokshonov, D., and Korshunov, A. (2017). Constructing and calculating of multistage sucker rod string according to reduced stress. *Acta Montanistica Slovaca*, Vol. 22, Issue: 2, p 107-115
Bronya Wiklund, Mehmet S. Kizil, Ismet Canbulat (2011). Development of a cavity prediction model for longwall mining. *Coal Operators' Conference 10-11 February 2011*. s.48-59
Herezy, Ł., Janik, D. and Skrzypkowski, K. (2018). Powered Roof Support – Rock Strata Interactions on the Example of an Automated Coal Plough System. *Studia Geotechnica et Mechanica*, 40(1): 46–55.

- Jing Xuan Yang, Chang You Liu and Bin Yu (2017). The interaction between face support and surrounding rock and its rib weakening mechanism in hard coal seam. *Acta Montanistica Slovaca* Volume 22, number 1, 67-78
- Jingyi Cheng, Zhijun Wan, and Yinlin Ji, (2018). Shield-Roof Interaction in Longwall Panels: Insights from Field Data and Their Application to Ground Control. *Advances in Civil Engineering*, vol. 2018, Article ID 3031714, 18 pages. <https://doi.org/10.1155/2018/3031714>.
- Kalentev, E., Vaclav, S., Bozek, P., Tarasov, V. and Korshunov, A. (2017). Numerical analysis of the stress-strain state of a rope strand with linear contact under tension and torsion loading conditions. *ADVANCES IN SCIENCE AND TECHNOLOGY-RESEARCH JOURNAL*, Vol. 11, Issue: 2, p 231-239
- Langosch, U., Ruppel, U., Wyink, U. (2003). Longwall roof control by calculation of the shield support requirements. In: *Proceedings of the Coal Operators' Conference*, 162–172
- Qazizada, E. Pivarčiová, E. (2018). Reliability of parallel and serial centrifugal pumps for dewatering in mining process. *Acta Montanistica Slovaca*, Vol. 23, Issue 2, p. 141-152
- Płonka, M. (2009). Zmienność obciążenia sekcji obudowy w ścianie zawałowej. *Prace naukowe GIG Górnictwo i środowisko, kwartalnik*, nr 1/2009. p. 41-49
- Płonka, M. and Rajwa, S. (2018). Utrudnienia w prowadzeniu sekcji obudowy zmechanizowanej obserwowane podczas pracy w dolnym zakresie jej wysokości roboczej, *Mining – Informatics, Automation and electrical Engineering* 4 (536) 2018 p. 55-64
- PRASS III project website: www.prass3.komag.eu
- Prusek, S., Płonka, M. and Walentek, A. (2016). Applying the ground reaction curve concept to the assessment of shield support performance in longwall faces. *Arab J Geosci*. 9: 167. <https://doi.org/10.1007/s12517-015-2171-2>
- Prusek, S., Rajwa, S., Wrana, A. and Krzemień, A. (2017). Assessment of roof fall risk in longwall coal mines, *International Journal of Mining, Reclamation and Environment*, 31:8, 558-574, DOI: 10.1080/17480930.2016.1200897
- Rajwa, S., Prusek, S., Szuścik, J. and Gąska, R. (2017). Prowadzenie ściany pod gruzowiskiem zawałowym w warunkach zmiennej grubości pozostawionej warstwy przyspągowej, *Przegląd Górniczy* 6/2017 p. 33-37
- Stankiewicz, K. (2018). Górnicze systemy sterowania i automatyzacji rozproszonej. *Journal of Machine Construction and Maintenance*. Nr 2/2018 (109). s. 117-122.
- Szurgacz, D. and Brodny, J. (2019). Tests of Geometry of the Powered Roof Support Section. *Energies*, 12, 3945. <https://doi.org/10.3390/en12203945>
- Szweda, S., Szyguła, M. and Mazurek, K. (2016). Czynniki wpływające na postać konstrukcyjną i parametry techniczne sekcji ścianowej obudowy zmechanizowanej. Część 1. Monografia Instytut Techniki Górniczej KOMAG, Gliwice 2016.
- Szyguła, M. (2013). Rozwój konstrukcji sekcji obudowy zmechanizowanej w górnictwie węgla kamiennego w Polsce. *Maszyny Górnicze* nr 2/2013. s. 30-38.
- Wang, J., Ning, J., Jiang, L., Jiang, J-Q., and Bu, T.. (2018). Structural characteristics of strata overlying of a fully mechanized longwall face: a case study. *Journal of the Southern African Institute of Mining and Metallurgy*, 118(11), 1195-1204. <https://dx.doi.org/10.17159/2411-9717/2018/v118n11a10>
- Witek, M., Prusek, S. (2016). Numerical calculations of shield support stress based on laboratory test results. *Computers and Geotechnics* 72, p. 74–88
- Verma, A.K., Kishore, K. and Chatterjee, S. (2016). Prediction Model of Longwall Powered Support Capacity Using Field Monitored Data of a Longwall Panel and Uncertainty-Based Neural Network. *Geotech. Geol Eng* 34: 2033. <https://doi.org/10.1007/s10706-016-0081-z>
- Yang, Y., Zeng, Q., Zhou, J., Wan, L., and Gao, K. (2018). The design and analysis of a new slipper-type hydraulic support. *PLoS ONE* 13(8):e0202431. <https://doi.org/10.1371/journal.pone.0202431>